

МІНІСТЕРСТВО ОСВІТИ І НАУКИ УКРАЇНИ  
ЧЕРНІГІВСЬКИЙ НАЦІОНАЛЬНИЙ ТЕХНОЛОГІЧНИЙ УНІВЕРСИТЕТ

# **АНГЛІЙСЬКА МОВА В ЕЛЕКТРОНІЦІ**

**МЕТОДИЧНІ ВКАЗІВКИ**

до практичних занять  
для студентів денної форми навчання  
спеціальності 171 “ЕЛЕКТРОНІКА”

Обговорено і рекомендовано  
на засіданні кафедри  
іноземних мов професійного спрямування  
*Протокол № 7 від 23 лютого 2018 р.*

**ЧЕРНІГІВ ЧНТУ 2018**

Англійська мова в електроніці. Методичні вказівки до практичних занять для студентів денної форми навчання спеціальності 171 «Електроніка» / Укл. Пермінова В.А., Сікалюк А.І.– Чернігів : ЧНТУ, 2018. – 72 с.

- Укладачі: ПЕРМІНОВА ВЛАДИСЛАВА АНАТОЛІЇВНА,  
кандидат педагогічних наук, доцент кафедри  
іноземних мов професійного спрямування  
СІКАЛЮК АНЖЕЛА ІВАНІВНА, кандидат  
педагогічних наук, доцент кафедри іноземних мов  
професійного спрямування;
- Відповідальна за випуск: ЛИТВИН СВІТЛАНА ВОЛОДИМИРІВНА,  
завідувач кафедри іноземних мов професійного  
спрямування, кандидат педагогічних наук, доцент
- Рецензент: ЛИТВИН СВІТЛАНА ВОЛОДИМИРІВНА,  
завідувач кафедри іноземних мов професійного  
спрямування, кандидат педагогічних наук, доцент

Передмова.....	4
<b>Part I</b>	<b>5</b>
1. YOUR CAREER AS AN ELECTRICAL ENGINEER	5
1.1 The Bologna process in the department of electrical engineering.....	6
1.2 The engineering profession.....	8
1.3 The structure of matter.....	10
2 THE ELECTRIC CURRENT.....	14
2.1 The effects of an electric current.....	14
2.2 Electric circuits .....	18
2.3 Conductors, insulators, semiconductors .....	22
3 BATTERIES AND CAPACITORS.....	24
3.1 Process control systems.....	27
3.2 DC motor .....	28
3.3 From camera to screen .....	29
3.4 The cathode ray tube.....	30
4 RADIO COMMUNICATIONS .....	33
4.1 How robots make our lives easier .....	36
4.2 Circuit breakers, fuses and switches .....	38
4.3 Power engineering .....	44
5 TELECOMMUNICATIONS.....	
5.1 Optical fibers .....	46
5.2 Nikola Tesla – the genius who lit the world.....	48
5.3 Nanotechnology .....	49
<b>Part II</b>	<b>51</b>
1. How to write application form.....	51
2. How to write a summery .....	53
3. How to write a power point presentation .....	54
4. How to write a business letter.....	58
<b>Part III</b>	<b>60</b>
Glossary.....	60
References .....	72

## Передмова

Методичні вказівки «Англійська мова у електроніці» складені у відповідності до вимог Програми викладання англійської мови за професійним спрямуванням та призначені для студентів денної форми навчання на пряму підготовки 171 “Електроніка” немовних вузів, які продовжують вивчення англійської мови на базі знань, отриманих в середній школі. Головна мета методичних вказівок – розвиток умінь розуміння й аналізу текстів, накопичення словникового запасу, уміння вести бесіду, брати участь у дискусіях англійською мовою, формувати позицію фахівця іноземною мовою в галузі електроніки.

Методичні вказівки включають два основних розділи, які містять неадаптовані професійно-орієнтовані тексти, комплекс комунікативно-спрямованих завдань, які сприятимуть кращому оволодінню англійською мовою професійного спрямування, розвитку комунікативних навичок, а також вирішенню професійних завдань засобами іноземної мови.

Методичні вказівки доповнено глосарієм для фахівців у галузі електроніки, який представлений у третьому розділі.

## **PART 1**

### **1 YOUR CAREER AS AN ELECTRICAL ENGINEER**

Electrical engineering is a very broad discipline that addresses the design and understanding of devices, circuits, and systems that use electromagnetic waves in electronic or optical signals. This increasingly involves the use of computers, but focuses on the design and analysis of electronic/optical components and the signals that connect them.

The rapid expansion of the high tech industry has provided a wealth of professional opportunities for electrical engineers. Although, showing a chronic shortage of qualified electrical engineers, this is one of the fastest growing specialty areas of engineering. A degree in electrical engineering provides great flexibility and can lead to a wide range of career paths. Electrical engineers are inventors, designers, business owners, consultants, teachers, researchers, scientists, executives, politicians, and astronauts. They are addressing many of the world's most serious environmental and social challenges by developing new processes, more efficient resource use, and enhanced communication. Following the introduction of the Bologna process, which Croatia started implementing in 2005, it has become common for the higher education institutions to split technical studies into two parts. At the end of the first part lasting three years, students would get the bachelor's degree (baccalaureus abb. BSc, 180 ECTS) - in the Department of Electrical Engineering students obtain the qualification Bachelor of Electrical Engineering. The second part is an optional two years, so-called specialist study with the master's degree (abb. MSc, 120 ECTS). Electrical engineering is a profession that uses science, technology, and problem-solving skills to design, construct, and maintain products, services, and information systems. Electrical engineering is the historical name for what is now called electrical, electronics, and computer engineering.

Our electrical engineering program (see also the text Compulsory, basic, electives - courses for the first year students) includes more mathematics and science, such as mathematical statistics, analog circuits, elements of automation, electrical measurements, engineering mechanics, electrical machines, electronic circuits, switching equipment, transformers, linear and nonlinear circuits, fundamentals of telecommunications, programming, electrical power engineering, electrical power networks, electric motor drives, low-voltage installations and lightning, electric power plants, process measurements, protection in switchgear, electronic computers and computer equipment, optical communications, radio communication technique and systems, telecommunication networks, mobile radio communications, control devices and systems, radar systems. Some of these courses are compulsory and some of them are electives.

A Bachelor of Science degree in engineering with a specialty in electrical engineering may also serve as a starting point for careers in many other diverse fields, since the problem-solving skills acquired in an electrical engineering program provide an extraordinarily valuable asset. The same skills will equip you to assume leadership roles in your community and in professional circles outside the workplace. A Bachelor of Science program constitutes the full-time formal education for most engineering graduates and is usually undertaken in one field of engineering, which is sometimes noted in the degree post nominals, as in BE (Aero) or BEng (Elec).

Those of you who will continue studying, those who are interested in advanced design, development and research programs will get a Master's degree (MSc or M.Sc.) and those whose interest is focused on research will pursue a doctoral degree (PhD or Ph.D.).

**WRITE DOWN THREE REASONS WHY YOU HAVE CHOSEN THIS STUDY COURSE**

- 1.
- 2.
- 3.

**WRITE A SHORT ESSAY - HOW I SEE MY FUTURE**

A Bachelor of Engineering degree, BSc in other countries includes	BSc in the Department of electrical engineering, The Polytechnic of Kyiv
Electrical engineering Electronic and Electrical Engineering Electronic engineering Microelectronic and Electrical Engineering Electronics and Telecommunication Engineering	Control and computer engineering in automation  Electrical power engineering  Communication and computer technology

**YOU MIGHT BE AN ENGINEER IF...**

- the only jokes you receive are through e-mail.
- you can't write unless the paper has both horizontal and vertical lines
- you order pizza over the Internet and pay for it with your home banking software
- all your sentences begin with "what if"
- at Christmas, it goes without saying that you'll be the one to find the burnt-out bulb in the string
- buying flowers for your girlfriend or spending the money to upgrade your RAM is a moral dilemma
- people groan at the party when you pick out the music
- you are always late to meetings
- you are at an air show and know how fast the skydivers are falling.

**1.1 THE BOLOGNA PROCESS IN THE DEPARTMENT OF ELECTRICAL ENGINEERING**

The Department of Electrical Engineering is a continuation of the three-year Technical College founded in Kyiv in 1962 and almost four decades later, in 1998, it became one of the departments of the Polytechnic of Kyiv. The academic year 2005/2006 was the implementation of the Bologna process or the Bologna Declaration requirements in the Department of Electrical Engineering. Since a three- year bachelor degree (180 ECTS) should give students broad professional basic knowledge and competencies, their mobility and later on employability depend greatly upon and rely on cross disciplinary qualifications where foreign languages play an important role. Along with these indispensable cross-disciplinary qualifications and competences, regardless of the profile of each study course or higher education institution, in most EU countries compulsory knowledge of one or more foreign

languages is required. Discussing the Bologna Process with the special accent on employability of graduates, UNICE (Union of Industrial and Employers' Confederation of Europe, in 2007 renamed BUSINESSEUROPE) emphasizes that a bachelor should have:

- an appropriate level of verbal and written articulacy in the national language
- an appropriate level of verbal and written articulacy in at least one foreign language (preferably English for non-native speakers)
- ability to work in a team, etc.

Having all this in mind, it is an imperative for Ukrainian graduates to have a fluent foreign language competence, in both the oral and the written language. They should also master the particular language of their specialty.

To meet all these requirements and as computer skills are compulsory for all university graduates, the software for learning and testing English in a computer laboratory in the Department of Electrical Engineering has been created and different types of drills and tests have been prepared for students. These tests may also be used for self-study together with drills and tests on our web sites.

To familiarize the students with certain new terms concerning the Bologna process, the first year courses are listed here as well as the names for different types of courses, such as compulsory or basic (all first year courses, except the foreign language which is compulsory elective), electives (which students choose themselves), etc.

After you have passed the prescribed university entrance exam, you will have to deal with the following compulsory basic and compulsory elective courses in your first year:

1 <sup>st</sup> term	ECTS	2 <sup>nd</sup> term	ECTS
fundamentals of electrical engineering	8	fundamentals of electrical engineering 2	9
mathematics 1	7	mathematical tools for electrical engineering	2
Physics	5	mathematics 2	9
materials in electrical engineering	4	electronic components	6
personal computer applications	5	English in Electrical Engineering 1	2
technical documentation	3	physical education	1
physical education	1	<b>First year total ECTS 62</b>	

During the last term, students have practical training and write their final thesis. They are assigned a mentor who suggests which electives they should choose and approves the subject of the final thesis.

The last examination is actually the final thesis which students defend publicly in order to get a degree. The degree is: Bachelor of Engineering in Electrical Engineering abbreviated B.Eng.

#### *European Credit Transfer System = ECTS*

ECTS is based on the student workload required to achieve the objectives of the study programme (60 credits of a full-time student during one academic year). It was introduced in 1989 and it facilitated the recognition of periods of study abroad and thus enhanced the quality and volume of student mobility in Europe. It is one of the key objectives of the Bologna Declaration of June 1999.

ECTS makes study programmes easy to read and compare for all students, local and foreign.

ECTS facilitates mobility and academic recognition.

ECTS helps universities to organize and revise their study programmes.

ECTS can be used across a variety of programmes and modes of delivery.

ECTS makes European higher education more attractive for students from abroad.

## 1.2 THE ENGINEERING PROFESSION

**What is engineering?** It offers solutions for real human problems by the development and application of tools, machines, materials, goods, or information in the form of skills, knowledge, processes, blueprints, plans, diagrams, models, formulae, tables, engineering designs, specifications, manuals, or instructions.

What is the work of an engineer? An engineer **designs, operates, or maintains** certain kinds of equipment, **deals with** the practical application of theoretical findings. Engineers **apply** the principles of science and mathematics to develop economical solutions to technical problems. Their work is the link between social needs and commercial applications.

However, what an engineer did in the past, may seem strange and funny today. You know that in the past engineers did not go to school, don't you? They just worked for a number of years to be taught certain skills. But, that's ancient history, times have drastically changed.

**Today's engineers** require at least a **three- or five-year university course** in order to graduate at a college or to get a bachelor's degree in engineering and become specialists in their fields. This does not mean that, taking their degree, the education is finished. **Continuing education**, or as it has been called lately **lifelong learning**, is critical for engineers wishing to enhance their value to employers as technology evolves. They have to cover different fields, incorporate their ideas into the real world, listen to the needs, and be familiar with the global economic situation.

Therefore, when engineers start developing a new product, they have to consider many factors. For example, in developing **an industrial robot**, engineers precisely specify the **functional requirements; design and test** the robot's components; **integrate** the components to produce the final design; and **evaluate** the design's overall **effectiveness, cost, reliability, and safety**. This process applies to the development of many different products, such as chemicals, computers, gas turbines, helicopters, and toys.

In addition to design and development, many engineers work in testing, production, or maintenance. These engineers **supervise** production in factories, **determine** the causes of component failure, and **test** manufactured products to **maintain quality**. They also **estimate the time and cost** to complete projects. Some move into **engineering management** or into **sales**. In sales, an engineering background enables them to **discuss technical aspects** and assist in **product planning, installation, and use**. **Supervisory engineers** are responsible for major components or entire projects.

**Engineers use computers** extensively to **produce and analyse designs; to simulate and test** how a machine, structure, or system operates; and to **generate** specifications for parts. Many engineers also use computers to **monitor product quality and control process**





**efficiency.** The field of nanotechnology, which involves the creation of high-performance materials and components by integrating atoms and molecules, also is introducing entirely new principles to the design process.

**Most engineers specialize.** Numerous specialties are recognized by professional societies, and the major branches of engineering have numerous subdivisions. Some examples include structural and transportation engineering, which are subdivisions of civil engineering; and ceramic, metallurgical, and polymer engineering, which are subdivisions of materials engineering. Engineers also may specialize in one industry, such as motor vehicles, or in one type of technology, such as turbines or semiconductor materials.

### **FILL IN THE BLANK SPACES WITH THE CORRESPONDING ENGINEERING PROFESSION:**

- 1) a person whose job involves designing and building of houses, roads, bridges is a  
engineer
- 2) a person who designs and builds machines and systems that use or produce electricity  
is an \_\_\_\_\_ engineer
- 3) a person whose job is to design, build and repair machines is a \_\_\_\_\_ engineer
- 4) a person who writes computer programs is a \_\_\_\_\_ engineer
- 5) a person who works in a recording or a broadcasting studio and controls the levels and  
balance  
of sound is a \_\_\_\_\_ engineer

### **DISCUSSION QUESTIONS**

1. What is engineering?
2. What is the work of an engineer?
3. What is the difference between today's engineers and those in the past?
4. Why is continuous education an imperative for engineers?
5. What tasks does a supervisory engineer perform?
6. What do engineers use computers for?
7. Where would you like to work?
8. What would you like to specialize in?

### **TRANSLATE INTO UKRAINIAN**

**Engineers trained in one branch may work in related branches** and this flexibility allows them to shift to fields with better employment prospects or to those that more closely match their interests. As far as electrical and electronics engineers are concerned, and they are the most important here, there is a certain difference between them.

**Electrical engineers** design, develop, test, and supervise the manufacture of electrical equipment. This equipment includes electrical motors; machinery controls, lighting, and wiring in buildings; automobiles; aircraft; radar and navigation systems; power-generating, -controlling, and -transmission devices used by electric utilities. Although the terms "electrical" and "electronics" engineering are often used interchangeably, electrical engineers have traditionally focused on the **generation and supply of power**, whereas electronics engineers have worked on applications of electricity to control systems or signal processing. **Electrical engineers specialize in areas such as power systems engineering or electrical equipment manufacturing.**

**Electronics engineers** are responsible for a wide range of technologies, from portable music players to the global positioning system (GPS). Electronics engineers design, develop,

test, and supervise the manufacture of electronic equipment such as broadcast and communications systems. Many electronics engineers also work in areas closely related to computers. However, engineers whose work is related exclusively to computer hardware are considered computer hardware engineers. **Electronics engineers specialize in areas such as communications, signal processing, and control systems** or have a specialty within one of these areas—industrial robot control systems or aviation electronics, for example.

**Engineers** should be **creative, inquisitive, analytical, and detail oriented**. They should be able to work as part of a team and to communicate well, both orally and in writing. **Communication abilities** are important because engineers often interact with specialists in a wide range of fields outside engineering.

### 1.3 THE STRUCTURE OF MATTER

Our world consists of many things that we call **matter**. Matter means anything that has weight and takes up space. It appears in four forms, i.e. the **solid state**, for example stones, the **liquid state**, such as water, the **gaseous state**, air, for example, and **plasma**, such as electrical arcs produced by tesla coils.

This variety represented a puzzle which was difficult to understand and solve. People thought about matter, made experiments but the **first theory** appeared only at the beginning of the nineteenth century. It was **John Dalton**, an English scientist, who stated that all matter is made up of small indivisible particles, and he called them **atoms**. The word atom comes from the Greek word *atomos*, meaning indivisible. This theory of the atomic nature of matter was true for a long time. Scientists found **92 different atoms** from which all matter in nature was composed.

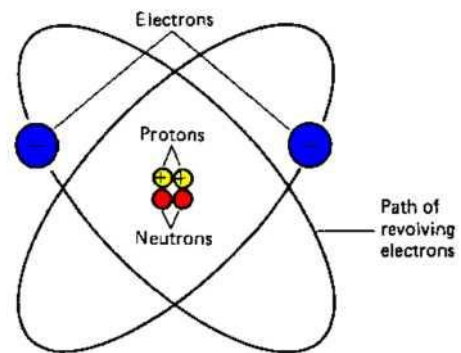

Almost a hundred years later, another English scientist, **Sir J. J. Thomson** developed and published his theory of a **subatomic particle**. At first it was called a corpuscle but later, **G. J. Stoney**, an Irish physicist gave it another name, **electron**.

So, if we want to define what an atom is, we may say: **an atom is the basic unit of matter** and it consists of a **nucleus** around which smaller particles orbit. These particles are **electrons** and have a **negative electric charge**. The nucleus is made up of **protons** and **neutrons**. Protons are positively charged whereas neutrons have no net charge.

Each atom contains an equal number of electrons and protons but may have a different number of neutrons. **Mass number** is the sum of protons and neutrons of an atomic nucleus, while **atomic number** is the number of elementary positive charges in the nucleus when an atom is in its normal condition. The atomic number varies for each element, e.g. it is **1** for hydrogen (the lightest element in nature), and **92** for uranium (the heaviest element in nature) but the number is even higher for the new **artificial elements**. **Copper**, for example, which is one of the most important elements in electricity contains **29** electrons and **29** protons, and thus its atomic number is **29**.

We can compare the structure of an atom to the **Solar system**. Electrons, which have only a very small mass<sup>1</sup> in comparison to protons and neutrons, orbit at a very rapid speed

<sup>1</sup> let's "see" how tiny an electron is: If an ampere is defined as the number of electrons passing through a point in one second, then the number of electrons per ampere is 6.280.000.000.000.000.000 (6.28 x 10<sup>28</sup>)

around the nucleus, somewhat in the same manner as the Earth and the other planets orbit around the Sun. These are planetary electrons and they revolve around the positively charged nucleus of their atom.

Fig. 1 represents the theoretical structure of the helium atom. Its nucleus contains two protons and two neutrons. The two planetary electrons revolve in the orbit around the nucleus. But, besides planetary electrons, which are, due to their negative charge strongly attracted to the positively charged nucleus, there is another type of electrons. These are free electrons. They move freely in matter or a vacuum when external electric or magnetic fields act on them. The free electrons are important in electricity and one simple definition for electric current says:

**"An electric current is the continuous flow or movement of free electrons."**

### **TERMS AND DEFINITIONS**

**orbital or planetary electron** - an electron that moves in orbit around the nucleus of an atom

**atomic number** - the number of elementary positive charges in the nucleus of an atom, it is a different number for each element, starting with 1 for hydrogen and going up beyond 103

**free electron** - an electron that is not constrained to remain in a particular atom, it is therefore able to move freely in matter or a vacuum, when acted on by external electric or magnetic field

**subatomic** - pertaining to particles smaller than atoms, such as electrons, protons and neutrons

**current** - the rate of transfer of electricity from one point to another; current is usually a movement of electrons, but may also be a movement of positive and negative ions, or holes

**copper** - a metallic element that has excellent conductivity of heat and electricity, good ductility and malleability, it is easily alloyed

**electron** - a subatomic particle with a negative electric charge **conductor** - a material which permits the flow of free electrons **generator** - an electric machine for generating electromotive force (voltage)

**like charges** (+ & + and - & -) - repel each other **unlike charges** (+ & -) - attract each other

**electron flow** - a current produced by the movement of free electrons toward a positive terminal; the direction of electron flow is opposite to that current

### **DISCUSSION QUESTIONS**

1. What is matter?
2. How many states of matter are there?
3. Who was the first author of the theory of matter and when did it appear?
4. What did John Dalton state?
5. Why did he call his particles "atoms"?
6. How many different types of atoms are there?
7. What did J. J. Thomson discover?
8. What other name did Stoney give Thomson's particle?
9. What is an atom?
10. What does a nucleus consist of?
11. What does the number of protons in a nucleus determine?
12. What are the properties of copper?
13. Why can the structure of an atom be compared to the Solar system?
14. Why are planetary electrons strongly attracted to the positively charged nucleus of their atom?

15. What happens when external electric or magnetic forces act on free electrons?
16. What does the movement of free electrons provide?

**TRANSLATE INTO UKRAINIAN**

**ELECTRONS AND ELECTRICITY**

More than two thousand years ago the Greek philosopher Thales observed that when a piece of amber, a hardened gum from trees, was rubbed with a material like wool or fur, it attracted certain other kinds of materials. This ability to attract (and also to repel, as it was later discovered) other objects is due to **electric charge**. The phenomenon itself came to be called **static electricity**. "Electricity" comes from the Greek word for amber, "static" indicates that the charge remains stationary, that is, it remains bound to the material that has been charged.

It was many hundreds of years before any further significant observations were made about the phenomenon of static electricity. Then it was discovered that many other materials beside amber could be charged by rubbing, which produced friction. A more important discovery was that there were **two kinds of electrical charges**. These two kinds of charges were called **positive** and **negative**. A positive charge was indicated by a plus sign (+) and a negative charge by a minus sign (-). These symbols are still in universal use today. It was also discovered that like charges - two positive charges or two negative charges - repelled each other, whereas unlike charges - a positive and a negative charge - attracted each other.

Much later it was learned that the movement of tiny particles of matter called electrons **caused electricity**. The electron is one of the particles that make up atoms, the basic units of matter of which a chemical element is composed. The centre of the atom is a nucleus which contains almost the entire weight or mass of the atom. The nucleus itself consists of two different particles, protons and neutrons.

**The Solar System**

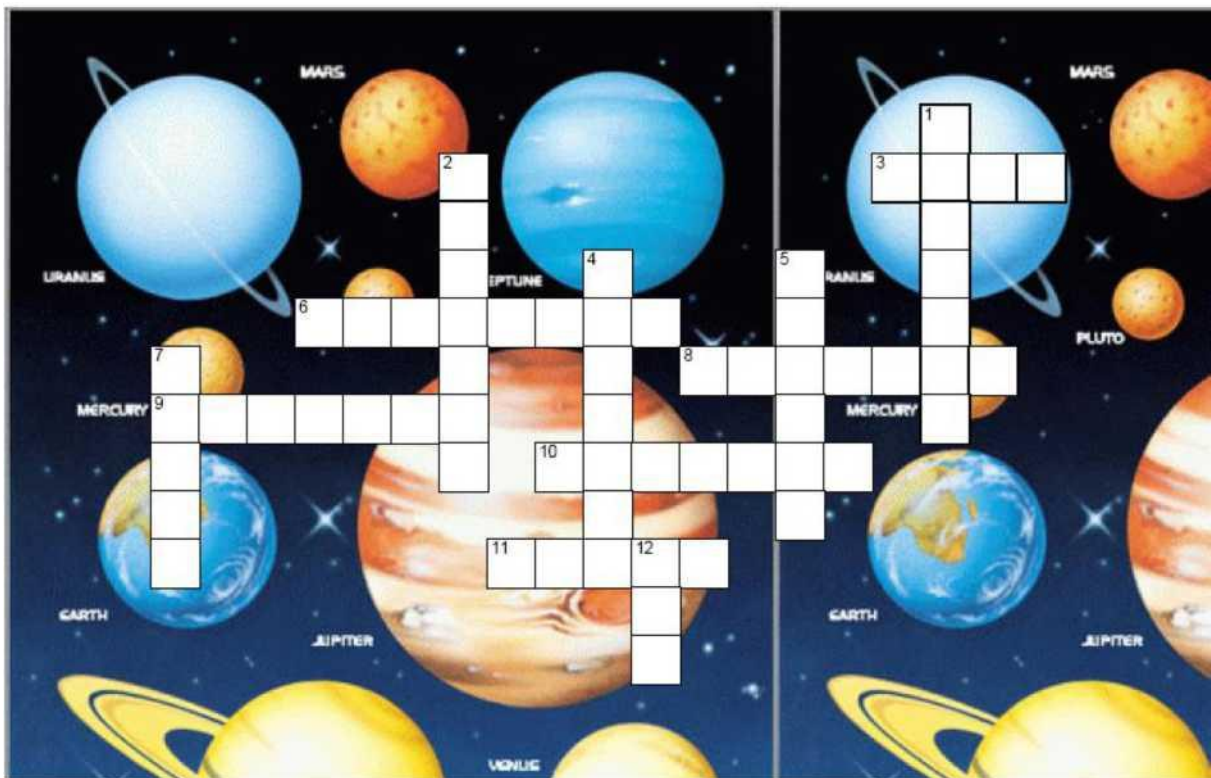

Use the following adjectives: big, light, heavy, bright, hot, long

**Across**

- 3 Neil Armstrong was the first man to land on the \_\_\_\_\_ .
- 6 The Sun is \_\_\_\_\_ than other planets.
- 8 The Sun is the \_\_\_\_\_ thing in the solar system.
- 9 There are nine \_\_\_\_\_ in the solar system.
- 10 The Earth is heavier than the Moon. The Moon is \_\_\_\_\_ than the Earth.
- 11 Captain Yang Liwei became the \_\_\_\_\_ Chinese man in space.

**Down**

- 1 The first planet is the \_\_\_\_\_ planet because it is nearest to the Sun.
- 2 The River Nile is the \_\_\_\_\_ river on Earth.
- 4 The Moon is lighter than the Earth. The Earth is \_\_\_\_\_ than the Moon.
- 5 The Earth is \_\_\_\_\_ than the Moon.
- 7 Yuri Gagarin was the first man in \_\_\_\_\_
- 12 The \_\_\_\_\_ is the brightest thing in the Solar system.

**COMPARISON** - Repeat the rules for comparison of adjectives and complete this table

<b>soft</b>		
	<b>easier</b>	
		<b>the most difficult</b>
<b>convenient</b>		
<b>large</b>		
	<b>farther</b>	
	<b>further</b>	

## 2 THE ELECTRIC CURRENT

### 2.1 THE EFFECTS OF AN ELECTRIC CURRENT

We have already noted that like, or similar charges repel each other, whereas unlike, or opposite charges attract each other. Thus, charged particles within a material are in the state of constant movement. But, when some external forces act on them, these charged particles may be made to move continuously in the same direction for some time. Such continuous movement is an electric current.

In 1862, Georg Simon Ohm, a German scientist, first established reliable and experimentally proved facts about electricity. He found the connection between the three values on which the transfer of electricity from one end of the conductor to the other depends. These three values,

**electromotive force  
current and  
resistance**

led to the postulation of the fundamental law in electricity: **Ohm's law**.

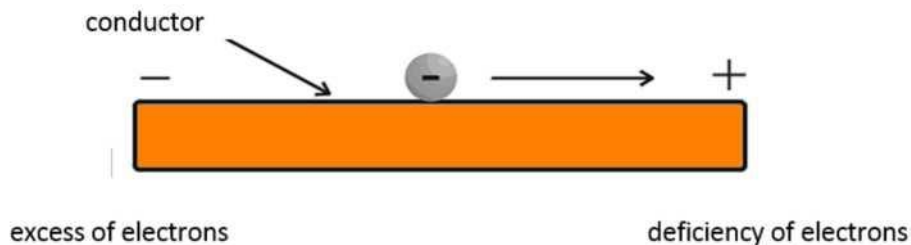

Figure 2 - Difference between amounts of potential energy makes electrons flow through a conductor

**Electromotive force** (abbreviated *EMF*), usually called **voltage** (*V*), is the force or pressure that moves electrons through a conductor. If electrons are piled at one end of the conductor, and if there are fewer electrons at the other end, the excess of electrons will flow toward the point of deficiency, i.e. **the current will flow through the conductor from the negative end to the positive one**. The **unit** of the electromotive force is the **volt, V**, named after the Italian scientist, Alessandro Volta.

The flow of electrons from one end of the conductor to the other is not always the same. On their way, they collide with atoms and molecules, atoms and molecules oppose them and that property of the conductor is called electric resistance. **The greater the number of free electrons in the conductor, the lower is its resistance.**

Most metals are good conductors, but the resistance of a conductor does not depend only on the **material** of which the conductor is made. It also depends on the **cross-section** of the conductor. **The greater the cross-section, the lower is the resistance of the conductor.** The third element is the **length** of the conductor. **The longer the conductor, the greater is its resistance.** And at last, there is the **temperature** of the substance. **If the temperature of a metal wire is higher, the resistance will be higher.** The **unit** of the resistance is the **ohm, Q**, named in the honour of G. S. Ohm.

*I* stands for **intensity**, strength or amount of **current**. It is, in fact, determined by the number or quantity of electrons which pass through the cross-section of a conductor per unit of time. The intensity depends upon the potential difference, and the resistance of the conductor.

**The greater the potential difference, the larger the quantity of electrons flowing through the conductor - the greater the resistance, the smaller the quantity of electrons.** The unit of the intensity is the **ampere, A**, named for a French scientist, André Ampère. The **relationship** between the voltage (**V**), the current (**I**), and the resistance (**R**) is stated in **Ohm's**

**The greater the electromotive force ( $R = \text{constant}$ ), the greater will be the current.**

**The greater the resistance ( $V = \text{constant}$ ) the smaller the current.**

**The current is directly proportional to the voltage and inversely proportional to the resistance.**

$$I = \frac{V}{R}$$

**law:**

### **DISCUSSION QUESTIONS**

- 1) How do like/unlike charges behave?
- 2) What happens when some external forces start acting on charged particles within the material?
- 3) What is an electric current?
- 4) What did G. S. Ohm find?
- 5) What is voltage?
- 6) How do electrons flow through a conductor?
- 7) What makes electrons move through a conductor?
- 8) What is resistance?
- 9) Explain the relationship between the number of free electrons in the conductor and its resistance.
- 10) What does the resistance of a conductor depend on?
- 11) How does the resistance of a conductor depend on:
  - a) the material of which the conductor is made,
  - b) the cross-section,
  - c) the length and
  - d) the temperature?
- 12) What does the symbol "I" stand for?
- 13) What is the intensity of the current determined by?
- 14) State Ohm's law.

### **TRANSLATE INTO UKRAINIAN RRENT KILLS**

**Electric devices and circuits can be dangerous.** Safe practices are necessary to

prevent shock, fires, explosions, mechanical damage, and injuries resulting from the improper use of tools.

Perhaps the greatest of these hazards is **electrical shock**. A current through the human body in excess of 10 milliamperes can paralyse the victim and make it impossible to let go of a "live" conductor. Ten milliamperes is a small amount of electrical flow: It is *ten on one thousandths* of an ampere. An ordinary flashlight uses more than 100 times that amount of current! If a shock victim is exposed to currents over 100 milliamperes, the shock is often *fatal*. This is still far less current than the flashlight uses.

A flashlight cell can deliver more than enough current to kill a human being. Yet it is safe to handle a flashlight cell because the resistance of human skin normally will be high enough to greatly limit the flow of electric current. Human skin usually has a resistance of several hundred thousand ohms. In low-voltage systems, a high resistance restricts current flow to very low values. Thus, there is little danger of an electrical shock.

**High voltage**, on the other hand, can force enough current through the skin to produce a shock. The danger of harmful shock increases as the voltage increases. Those who work on very high-voltage circuits must use special equipment and procedures for protection.

When human skin is moist or cut, its resistance can drop to several hundred ohms. Much less voltage is then required to produce a shock. Potentials as low as 40 volts can produce a fatal shock if the skin is broken! Although most technicians and electrical workers refer to 40 volts as a *low voltage*, it does not necessarily mean *safe voltage*. Obviously, you should be very cautious even when working with the so-called low voltages.

**Safety is an attitude; safety is knowledge.** Safe workers are not fooled by terms such as *low voltage*. They do not assume protective devices are working. They do not assume a circuit is off even though the switch is in the OFF position. They know that the switch can be defective. Before they act, they **investigate**, they **follow procedures**, when in doubt, they do not act, and they **consult their instructor**.

**PUT IN THE MISSING WORDS** (the same words may be used several times)

negative /electron(s) / battery/ flow/ attract/ positive/ pump/ terminal/ repel/ current circuit/ negatively/ components
---

An electric current is a \_\_\_\_\_ of \_\_\_\_\_ charged particles called \_\_\_\_\_ flowing through the wires and electronic \_\_\_\_\_ built-in \_\_\_\_\_ the electric

\_\_\_\_\_. It can be compared to the \_\_\_\_\_ of water through pipes, radiators etc. As water is pushed through pipes by a \_\_\_\_\_, electric current is pushed through wires by a \_\_\_\_\_.

Like charges \_\_\_\_\_ each other and unlike charges \_\_\_\_\_. Two negatives will \_\_\_\_\_ each other. A \_\_\_\_\_ and a \_\_\_\_\_ will \_\_\_\_\_ each other.

The negative terminal of a battery will push \_\_\_ along a wire. The positive terminal of



a \_\_\_\_\_ along a wire. Electric terminal \_\_\_\_\_ of a battery, through the battery will \_\_\_\_\_ negative will \_\_\_\_\_ therefore flow from the \_\_\_\_\_ lamp, to the positive \_\_\_\_\_ .

The effects of an electric current are **thermal, luminous, chemical** and **magnetic**. When a current flows through a conductor **it may heat the conductor**. This heat is sometimes undesirable and has to be reduced. For this reason many electric motors and generators contain **a fan**. However, domestic appliances, such as electric cookers, and many industrial processes depend on the heating effect of an electric current. The passage of a current **may produce light**. This can happen in a number of ways. The heat generated by the current may be so great that the conductor becomes **incandescent**. For example, the filament of a light bulb emits intense white light when heated by a current. Light is also produced when a current ionizes a gas. The colour of the light will vary according to the gas used. Mercury vapour lamps give a greenish-blue light. An electric current can separate a chemical compound into its components. This is called **electrolysis**. Chlorine is generated by the electrolysis of salt water. Electrolysis can also be used to break down water into hydrogen and oxygen. Because pure water does not conduct well, sulphuric acid has to be added before the electrolysis takes place.

A current flowing through a conductor creates a magnetic field around it. This field has three applications. It can magnetize magnetic materials and attract them to the conductor. The electric relay works on this principle. If the magnetic field is cut by another conductor, an electromotive force will be induced in that conductor. For instance, the change in current flowing through the primary of a transformer will induce a current in the secondary. This principle is also used in generators. Thirdly, if a current-carrying conductor is placed in the magnetic field, a force will be exerted on it. This effect is utilized in the electric motor.

## TERMS AND DEFINITIONS

**incandescence** - emission of visible radiation by a heated object, such as a lamp filament heated by electric current

**ionization** - a process by which a neutral atom or molecule loses or gains electrons, thereby acquiring a net charge and becoming an ion; it can be produced by collision of particles, i.e. by collisions between electrons and residual gas molecules in an electron tube (=ionization current or gas current), by radiation, and by other means

**electrolysis** - the production of chemical changes by passing current from an electrode to an electrolyte, or vice versa

**primary winding** - symbol P, the transformer winding that receives signal energy or AC power from a source; also called primary

**secondary winding** - symbol S, a transformer winding that receives energy by electromagnetic induction from the primary winding. A transformer may have several secondary windings, and they may provide AC voltages that are higher, lower, or the same as that applied to the primary winding; also called secondary.

**electromagnetic induction** - the production of a voltage in a coil by a change in the number of magnetic lines of force passing through the coil

## DISCUSSION QUESTIONS

1. What effects does an electric current produce?
2. What happens when an electric current passes through a conductor?
3. Why does the heat produced by an electric current have to be reduced and how can it be reduced?
4. Why does the conductor become incandescent when the current passes through it?
5. What happens when a current ionizes a gas?
6. What is electrolysis?
7. What does a current flowing through a conductor create around it?
8. What are the three applications of the magnetic field?

## SCRAMBLED SENTENCES (begin the sentence with the word in a capital letter):

1. through, causes, changes, a liquid, current, The passage of, an electric, chemical
2. current, Hans Christian Oersted, was, The magnetic, discovered, by, in, effect of, 1820, an electric,
3. electrolysis, application of, Electroplating, a common, is,
4. electric motors, voltmeters, many, current, electromagnets, applications, loudspeakers, effect of, an electric, has, The magnetic, e.g., etc.
5. explains, current, Ohm's, the relationship, voltage, existing, Law, between, resistance, and
6. Ohm's Law says: a circuit, proportional, voltage, The current, in, directly, proportional, is, resistance, and, to the amount of, inversely, of, to the applied
7. around, When, a magnetic, current, through, formed, a wire, flows, the wire, around, is, field
8. Joule effect is, effect, by the flow of, through, a resistance, the heating, of current, produced,
9. containing, heat, in a circuit, resistors, current, in, An electric, generates

## 2.2 ELECTRIC CIRCUITS

In the same way as water flows from a point of high potential energy to a point of low potential energy (i.e. from full to empty), so the electric current flows from a high-potential (excess of electrons) to a low-potential point (deficiency of electrons). The current may flow through solid conductors, liquids, gases, a vacuum or any combinations of these and that path of the electric current is called the electric circuit.

The simplest electric circuit contains only three parts, i.e. one load, one voltage source, and one control device. Most complete electric circuits contain six parts:

1. an energy source to provide the voltage needed to force current (electrons) through the circuit,
2. conductors through which the current can travel,
3. insulators to confine the current to the desired paths,
4. a load to control the amount of current and convert the electric energy taken from the energy source
5. a control device, often a switch, to start and stop the flow of current and
6. a protection device to interrupt the circuit in case of a circuit malfunction.

Examples of energy sources are dry cells, accumulators, or generators. Conductors are wires, cables, or other bodies or medium suitable for carrying electric current. An insulator is a

device that has high electric resistance, for supporting or separating conductors to prevent undesired flow of current from the conductors to other objects. A load is a device that consumes electric power, e.g. lamps, motors, household appliances etc. A control device, often a switch, is used to start or stop the flow of current. A protective device, i.e. a fuse, which is inserted in series with the circuit being protected, opens the circuit automatically during a serious overload.

These devices, as well as conductors, offer some resistance to the current. It may be high or low and depends on the type of the circuit and the kind of load that has been used. We have already learned what the resistance of a conductor depends on, so now several general types of circuits and their schematic diagrams will be considered.

Basic types of circuits differed by the type of the connection are a series circuit, a parallel circuit, and a complex circuit (e.g. series parallel circuit). The series circuit offers a single, continuous, path for current flow from the negative side of the electromotive force source to the positive one. The pieces of equipment or different electrical devices are connected by wires that give only one path to follow. In the diagram of a simple circuit Fig. 3, the symbol on the left indicates the source of electric current, and the symbol on the right indicates the source of resistance, e.g. a light bulbs.



Figure 3 - A schemmatic representing a simple electrical circuit

In a parallel circuit, two or more bulbs are placed parallel to each other so that the current has more than one path through which it can flow. In that way, as it is shown in the Fig. 5, the current is divided up among the three resistors. If one burns out, the current will flow through the other two. Household electricity is connected by parallel circuits so that the

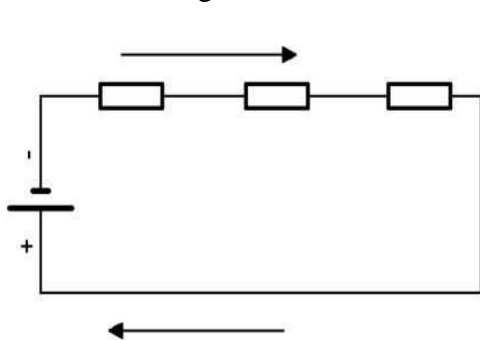

Figure 4 - A series circuit with three resistors

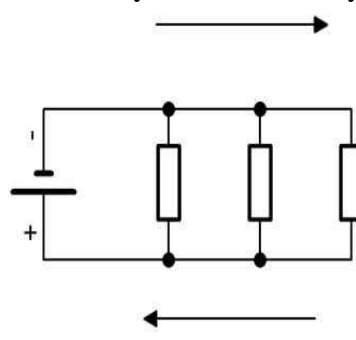

Figure 5 - A parallel circuit

whole circuit does not fail if one piece of electrical equipment burns out.

The two kinds of circuits can also be used together in a series parallel circuit. The Figures 6 and 7 show two possible arrangements. In order to set up a circuit, it is necessary to have sufficient voltage for

overcoming the resistance. Here, Ohm's law becomes a useful and necessary tool for electrical engineers.

Electrical circuits have to be protected. If there are too many electrical devices, the conducting wire may overheat and cause fire or serious injuries. To prevent this, fuses, through which all the current in the circuits passes, are built into the circuits.

A fuse is an intentionally weakened element that opens the circuit automatically if it is

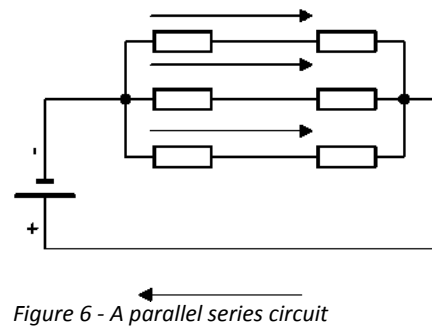
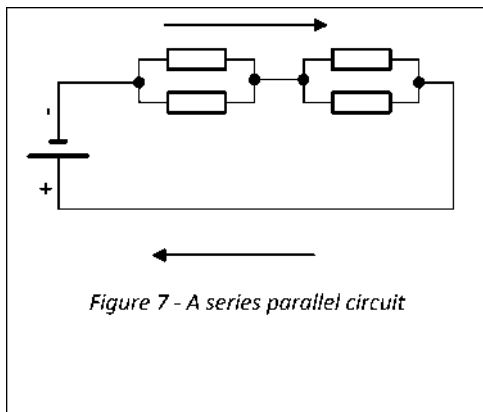

overloaded. It has a wire with a low melting point and when the fuse heats up, the wire melts and the circuit is broken.

**TERMS AND DEFINITIONS circuit** - arrangement of one or more complete paths for electron flow; a closed loop of conductors through which charges can flow

**electromotive force** - the force that tends to produce an electric current in a circuit, usually called voltage

**resistance** - the opposition that a device or material offers to the flow of electrical current

**series circuit** - a circuit in which all parts are connected end to end to provide a single path for the current

**parallel circuit** - a circuit in which the same voltage is applied to all components, and the current is divided among the components according to their resistances and impedances

## DISCUSSION QUESTIONS

1. Why can the flow of electric current be compared to the flow of water?
2. What is an electric circuit?
3. What does the simplest electric circuit contain?
4. What are the six parts that most complete electric circuits consist of?
5. Give a few examples for each of them?
6. What do all these devices offer to the current flow?
7. What does the resistance of the conductor depend on?
8. What types of electric circuits are there?
9. What is a series circuit?
10. What happens if one bulb in a series circuit burns out?
11. What happens if one bulb in a parallel circuit burns out?
12. Why is household electricity connected by parallel circuits?
13. Why must electric circuits be protected?
14. What is a fuse and what is its function?

amplifier output, amplifier, battery, bicycle, cooker, dynamo, lamp, lathe, legs, loudspeaker, microphone, motor, supply
---

**PUT THE FOLLOWING WORDS IN THE RIGHT COLUMNS**

(Join the load and its source and add some of your own):

SOURCE	LOAD

**FINISH THE SENTENCES:**

1. A small wire or device inside a piece of electrical equipment that breaks and stops current if the flow of electricity is too strong is a \_\_\_\_\_ .
2. The complete path of wires and equipment along which an electric current flows is a \_\_\_\_\_ .
3. A circuit in which all parts are connected end to end to provide a single path for current is a \_\_\_\_\_ .
4. Household appliances are connected by \_\_\_\_\_ circuits.
5. A manual or mechanically actuated device for making, breaking, or changing the connections in an electric circuit is a \_\_\_\_\_ .
6. A drawing which uses only symbols to show how components are connected together is a \_\_\_\_\_ (two words).
7. A substance through which electric charges can easily flow is called a \_\_\_\_\_ .
8. A device for producing electrical current by moving a coil of wire in a magnetic field is a \_\_\_\_\_ .

## TRUE or FALSE

In **series** circuits:

- a) the voltage drops across each resistor \_\_\_\_\_
- b) the current changes as it passes through each individual resistor \_\_\_\_\_
- c) the voltage always remains the same \_\_\_\_\_
- d) the current is the same at any particular point on the circuit \_\_\_\_\_
- e) the total resistance is the sum of individual resistors \_\_\_\_\_

In **parallel** circuits:

- a) the current in one branch will not be the same as in other branches unless all the resistances are the same \_\_\_\_\_
- b) the voltage is not the same for each branch \_\_\_\_\_
- c) the sum of the current in each individual branch will add up to give the total current of the circuit \_\_\_\_\_
- d) the voltage is the same for each branch \_\_\_\_\_
- e) the voltage differs from the voltage of the power source \_\_\_\_\_

## 2.3 CONDUCTORS, INSULATORS, SEMICONDUCTORS

In electrical engineering materials may be classified into three groups, i.e. conducting materials, insulating materials and semi conducting materials depending on their ability to conduct electricity. The first category includes conductors, i.e. materials which provide an easy path for an electric current. Conductors are materials that obey Ohm's law and have very low resistance. We have already mentioned the electron theory which states that all matter is composed of atoms. Atoms consist of a small positive nucleus surrounded by a cloud of electrons. Conductors are materials where some of these electrons are free to move. These free electrons, considered identical to the outermost, or valence electrons, are not constrained to remain in a particular atom. They are able to move freely in matter or a vacuum when an external electric field acts on them. The electric conductivity of the material is dependent upon the atomic structure of the material of which the conductors are made. Normally, conductors have three or less valence electrons, insulators have five or more and semiconductors usually have four valence electrons. To end up with, the materials in which it is easy to get electrons to move and provide a flow of electric current, are conductors. They are mostly metals, such as copper, aluminium, silver, gold, etc.

Copper and copper-based alloys are unique in their desirable combination of physical and mechanical properties. Due to their high electrical and thermal conductivity, they are very important in electrical industry. Copper is widely used for cables, transformer windings etc. Although silver is a slightly better conductor than copper, it is too expensive for common use. Aluminium is not as good conductor as copper, but it is cheaper and lighter. It is resistant to atmospheric weathering and today it is the dominant metal for the transmission lines of electrical energy.

Materials which offer high resistance to current flow are called insulators. Even the best insulators do release an occasional free electron to serve as a current carrier. However, for most practical purposes we consider an insulator to be a material that allows no current flow through it. Common insulator materials used in electrical devices are paper, wood, plastics, rubber, glass etc. Notice that common insulators are not pure elements. They are materials in which two or more elements are joined together to form a new substance. In the process of joining together, elements share their valence electrons. This sharing of valence electrons is

called covalent bonding. It takes a lot of added energy to break an electron free of a covalent bond.

Between the extremes of conductors and insulators is a group of materials known as semiconductors. The basic property of a semiconductor is given by its name - it "conducts a little bit". A semiconductor will carry electric current, but not easily as a normal conductor. Semiconductors are midway between conductors and insulators. They are neither good conductors nor good insulators. Under certain conditions they allow a current to flow easily but under others they behave as insulators. Germanium and silicon are semiconductors. The total conductivity in semi conducting materials is the sum of electron current and hole current. Semiconductors are extremely important industrial materials, they are materials from which electronic devices such as transistors, diodes, integrated circuits, and solar cells are manufactured. Without them modern electronic technology would not be possible, it would be even inconceivable.

**TERMS AND DEFINITIONS electrical conductivity** - the ability of a material to conduct an electric current, as measured by the current per unit of applied voltage; it is the reciprocal of resistivity

**electrical resistance** - the measure of the difficulty of the electric current to pass through a given material; its unit is the ohm ( $\Omega$ )

**conduction band** - the unfilled energy levels into which electrons can be excited to become conductive electrons; a band that when occupied by mobile electrons, permits their net movement in a particular direction, producing the flow of electricity through the solid

**dopant or doping agent** - an impurity element added to a semiconductor material under precisely controlled conditions to create PN junctions required for transistors and semiconductor diodes

**integrated circuit (IC)** - a single semiconductor chip or wafer which contains thousands or millions of circuit elements per square centimetre

**transistor (Transfer resistor)** - an active semiconductor device that has three or more electrodes, i.e. emitter, base and collector; it can perform practically all the functions of tubes, including amplification and rectification

## DISCUSSION QUESTIONS

1. What materials are there in electrical engineering?
2. According to what has this classification been made?
3. What are conductors?
4. How many valence electrons do conductors have?
5. What metals are considered good conductors?
6. What are the most important properties of copper?
7. What is copper used for?
8. Say something about silver and aluminium.
9. Why is aluminium used for open wire lines?
10. What is an insulator?
11. Name some insulators.
12. What are semiconductors?
13. What is the difference between conductors and semiconductors regarding total conductivity?
14. What are semiconductors used for?

## FILL IN THE MISSING WORDS

aluminum atomic bars conductivity conductor copper electricity gold  
 insulators made metals power lines resistance sheets silver spans supports  
 tubes weight wire

is a major consideration, , with long

(some words may be used more than once)

1. The electrical \_\_\_\_\_ of matter is dependent upon the \_\_\_\_\_ structure of the material from which the \_\_\_\_\_ is \_\_\_\_\_ .
2. \_\_\_\_\_ have an extremely high \_\_\_\_\_ to the flow of
3. Some \_\_\_\_\_ are better conductors of \_\_\_\_\_ than others.
4. \_\_\_\_\_ is the best conductor, followed by \_\_\_\_\_ and \_\_\_\_\_
5. \_\_\_\_\_ is used where such as high-tension \_\_\_\_\_ between \_\_\_\_\_
6. Conductors are usually found in the form of \_\_\_\_\_, but may be in the forms of \_\_\_\_\_, \_\_\_\_\_ or \_\_\_\_\_

### 3 BATTERIES and CAPACITORS

Put simply, to produce electric current, electrons are needed and the device which does that and which even young children are very well familiar with is a battery. Batteries are cans full of chemicals that produce electrons. Chemical reactions that produce electrons are called electrochemical reactions. Batteries are used everywhere. Beside in electronic toys, you can find them in our cars, our PCs, laptops, portable MP3 players and cell phones.

A battery has **two terminals**. One terminal is marked (+), or positive, while the other is marked (-), or negative. In an AA, C or D cell (normal flashlight batteries), the ends of the battery are the terminals. In a large car battery, there are two heavy lead posts that act as the terminals.

**Electrons** collect on the negative terminal of the battery. If a wire is connected between the negative and positive terminals, the electrons will flow from the negative to the positive terminal as fast as they can.

Normally, some type of **load** is connected to the battery using the wire. The load might be something like a light bulb, a motor or an electronic circuit like a radio (Fig 8).

A chemical reaction inside the battery itself produces the electrons. The speed of electron production by this chemical reaction (the battery's **internal resistance**) controls how many electrons can flow between the terminals. Once you connect a wire, the reaction starts. Electrons flow from the battery into a wire, and must travel from the negative to the positive

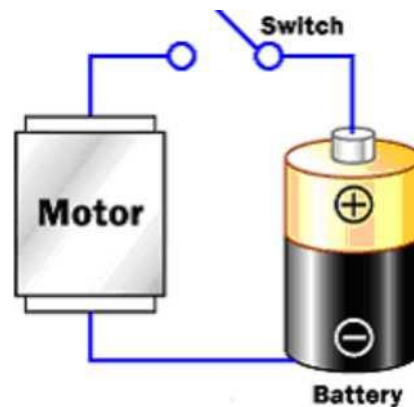
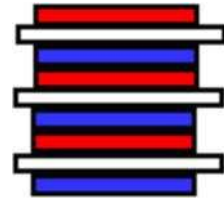

Figure 8 - Battery connected to a load



terminal for the chemical reaction to take place.

In 1800, the first battery was created by Alessandro Volta and the arrangement of that first battery was called after him - a **voltaic pile**. He made a stack by alternating layers of zinc, blotting paper soaked in salt water, and silver, like this shown in Figure 9.



- Zinc
- Silver □
- Blotter

Figure 9 - Voltaic pile

The top and bottom layers of the pile must be different metals. If a wire is attached to the top and bottom of the pile, a voltage and a current from the pile can be measured. If the pile is higher, each layer will increase the voltage by a fixed amount.

In a way, a **capacitor** is a little like a battery. Although they work in completely different ways, capacitors and batteries both store **electrical energy**. A capacitor is a much simpler device, and as distinguished from the battery, it cannot produce new electrons, it can only store them. This property of the capacitor is called **capacitance**. Let us find out what a capacitor is and how it is used in electronics.

Just like a battery, a capacitor has two terminals. The terminals are connected to two metal plates separated by a

dielectric. A dielectric is a material that can serve as an insulator because it has poor electric conductivity, e.g. it can be air, paper, plastic or anything else that does not conduct electricity and keeps the plates from touching each other.

When a capacitor is connected to a battery (Fig. 10), the plate on the capacitor that attaches to the negative terminal of the battery accepts electrons that the battery is producing, whereas the plate on the capacitor that attaches to the positive terminal of the battery loses electrons to the battery.

When **the capacitor is charged**, it has the same voltage as the battery (1.5 volts on the battery means 1.5 volts on the capacitor). Large capacitors can hold quite a bit of charge.

For example, when there is lightning in the sky, what you see is a huge capacitor where one plate is the cloud and the other plate is the ground, and the lightning is the charge releasing between these two "plates."

If a light bulb is connected into the circuit in Fig. 10 and if the capacitor is pretty big, the light bulb would light up as current flows from the battery to the capacitor to charge it up. The bulb would get progressively dimmer and finally go out once the capacitor reached its capacity. Then the battery is removed and replaced with a wire. Current would flow from one plate of the capacitor to the other. The light bulb would light and then get dimmer and dimmer, finally going out once the capacitor had completely discharged (the same number of electrons on both plates).

The unit of capacitance is a **farad**. Let us see how big 1 farad is. Plates would be 1130 km<sup>2</sup> each, the distance between them would be 1 cm, and dielectric would be air. In practice the unit is too big. Therefore capacitors are measured in microfarads (millionths of a farad).

**The difference between a capacitor and a battery** is that a capacitor can dump its entire charge in a tiny fraction of a second, whereas a battery would take minutes to

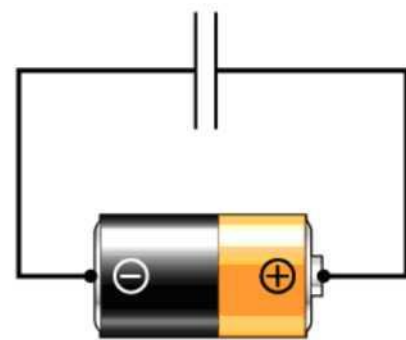

Figure 10 - Battery charging a capacitor

completely discharge itself. That is the reason why the electronic flash on a camera uses a capacitor. The battery charges up the flash capacitor over several seconds, and then the capacitor dumps the full charge into the flash tube almost instantly. This can make a large, charged capacitor extremely dangerous. Flash units and TVs have warnings about opening them up for this reason. They contain big capacitors that can, potentially, kill you with the charge they contain.

Capacitors are used to **store charge for high-speed use**, e.g. a flash, or big lasers to get very bright, instantaneous flashes. They **eliminate ripples**. If a line carrying DC voltage has ripples or spikes in it, a big capacitor can even out the voltage by absorbing the peaks and filling in the valleys. A capacitor can block DC voltage. If you hook a small capacitor to a battery, then no current will flow between the poles of the battery once the capacitor charges (which are instantaneous if the capacitor is small). However, any alternating current (AC) signal flows through a capacitor unimpeded. That's because the capacitor will charge and discharge as the alternating current fluctuates, making it appear that the alternating current is flowing.

## DISCUSSION QUESTIONS

1. What is a battery?
2. How are electrons produced?
3. Describe the process going on inside a battery.
4. When and who created the first battery?
5. What did the voltaic pile look like?
6. What is the difference between the battery and the capacitor?
7. What is dielectric?
8. What happens when a capacitor is connected to a battery?
9. What is the unit of capacitance?
10. Why are capacitors measured in microfarads?
11. What are capacitors used for?

## FILL IN THE GAPS WITH THE WORDS FROM THE BOX

batteries	cells	chemical	discharged	disposable	ecology
environmenta	once	pollution	reaction	rechargeabl	recharged
recycled	reversible	source	use up	wearing out	widespread

A battery is a DC voltage \_\_\_\_\_ and consists of one or more \_\_\_\_\_ which convert \_\_\_\_\_ energy into electric energy. There are two types of \_\_\_\_\_. These are primary or \_\_\_\_\_ and secondary or \_\_\_\_\_. Primary batteries can only be used \_\_\_\_\_ because they \_\_\_\_\_ their chemicals in an irreversible \_\_\_\_\_. Secondary batteries can be \_\_\_\_\_ because the chemical reactions they use are \_\_\_\_\_; they are recharged by running a charging current through a battery. Secondary batteries are called rechargeable because they can be charged and \_\_\_\_\_ many

times before wearing out. The \_\_\_\_\_ use of batteries has created many \_\_\_\_\_ problems, such as toxic metal \_\_\_\_\_. But, when \_\_\_\_\_ is concerned, it is important that after \_\_\_\_\_ some batteries can be \_\_\_\_\_.

### MAKE SENTENCES CONNECTING NUMBERS AND LETTERS

<ol style="list-style-type: none"> <li>1) A battery is ...</li> <li>2) There are two different types of cells ..</li> <li>3) Cells change ...</li> <li>4) Primary cells are thrown away ...</li> <li>5) Secondary cells ...</li> <li>6) The Zinc-carbon cell consists ...</li> <li>7) The zinc is ...</li> <li>8) Millions of cells are used every year ...</li> <li>9) The NiCad cell has a nickel anode ...</li> <li>10) Nickel-cadmium cells are ...</li> </ol>	<ol style="list-style-type: none"> <li>a) ... when the chemicals they contain are used up.</li> <li>b) ... the negative electrode.</li> <li>c) ... of zinc can which contains two chemicals.</li> <li>d) ... expensive, but can be recharged hundreds of times.</li> <li>e) ... in radios, torches, and tape recorders.</li> <li>f) ... a number of cells linked together.</li> <li>g) ... a cadmium cathode, and an alkaline electrolyte.</li> <li>h) ... chemical energy into electricity</li> <li>i) ... called primary and secondary cell</li> <li>j) ... can be recharged and used again and again.</li> </ol>
--	---

### 3.1 PROCESS CONTROL SYSTEMS

Control systems provide a means of **replacing human operators** in many industrial processes. They are widely used **to monitor** and **control** pressure, temperature, motor speed, the flow of a liquid, or any other **physical variable**. They must be capable of fulfilling a number of functions. First, the physical variable to be controlled, such as the air temperature in a factory or the pressure of the hydraulic system, must be measured. Then its value must be compared with the desired value. Next, action has to be taken to reduce to zero the difference between the actual and desired value.

The basic components of a control system are an **input transducer**, an **error sensor**, a **controller** and an **output transducer**. The input transducer converts changes in the physical variable into electrical signals.

Fig. 11 shows one type of transducer which converts changes in pressure to frequency changes. Pressure changes move the diaphragm in or out, thus altering the position of the ferrite core in Li which forms part of a tuned circuit. This causes the frequency of the circuit to change, thus altering the output frequency of the oscillator. The output is then fed to an error sensor. The error sensor measures the deviation between the actual and desired values for the variable.

The controller receives the error sensor output and uses it to control the variable either directly or indirectly. A simple controller is an electromagnetic relay which uses a small signal to control a much larger signal such as a power supply output.

The output transducer converts the electrical output from the controller into whatever form of energy is required to change the physical variable. It may be a valve, a heater, a motor or any electrically operated piece of equipment. An example is a motor-

operated valve which controls the flow of fluid in a pipeline.

Let us take as an example a process system for controlling the speed of a DC motor. The input transducer measures the speed and converts it into a voltage. The error sensor compares this voltage with the voltage across a speed-setting potentiometer. The error sensor output is fed to the controller which sends a signal to the power supply of the motor. This increases or reduces the supply of current to the motor, thus controlling its speed.

### Figure 11 DISCUSSION QUESTIONS

1. What does a control system provide?
2. Why are process control systems so important when human operators are considered?
3. What must a process control system be capable of doing?
4. What are the basic components of a control system?
5. Compare an input transducer with an output transducer.
6. What is the function of an error sensor?

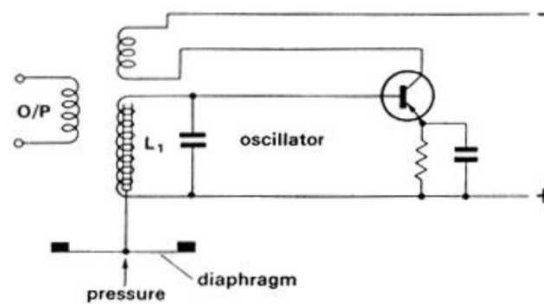

Figure 11

## TRANSLATE INTO UKRAINIAN

### 3.2 THE DC MOTOR

An electric motor is a machine for converting electrical energy into mechanical energy. Motors can be designed to run on direct (dc) or alternating current (ac). Let's first discuss the main features of a dc motor. Its' most important parts are the rotor, the stator and the brush-gear.

The rotor is the moving part. It contains an armature, which is a set of wire loops wound on a steel core. The armature and core are mounted on a shaft which runs on bearings. It provides a means of transmitting power from the motor.

The rotor also contains a commutator. This consists of a number of copper segments insulated from one another. The armature windings are connected with the commutator. Brushes are contacts made of mechanically soft material and glide on the commutator surface, enabling the current flow through the armature windings. As the rotor turns, the commutator acts as a switch making the current in the armature alternate.

The stator does not move. It consists of magnetic and electrical conductors. The magnetic circuit is made up of the frame and the poles. The field coils are wound round the poles. These form the stator's electrical circuit. When current is fed to them, a magnetic field is set up in the machine.

The motor operates on the principle that when a current-carrying conductor is placed in a magnetic field, a force is produced on the conductor. The interaction of the forces produced by the magnetic field of the rotor and the stator makes the rotor spin.

### 3.3 FROM CAMERA TO SCREEN

A television camera contains a **lens system** which is used to focus an image of the object on to the face of the camera tube. This tube contains a **photo-cathode** which emits electrons in response to light. The brighter the light from the image, the more electrons are emitted by the photocathode. In a black and white camera, the photo-cathode responds only to brightness, hence it is at this point that information on the colour of the image is lost. The electrons from the cathode are now made to strike a target electrode causing some of its atoms to become positively charged.

The target electrode is scanned by an electron beam. The beam sweeps the target electrode in a series of closely spaced lines. There are 405 or 625 of these lines depending on the system used. Fig. 13 represents the scan path of the beam.

When the beam reaches the end of the top scan line, it is brought quickly back to the beginning of the next line which is slightly lower. This return is called **fly-back** and is much quicker than a line scan.

The scanning beam loses electrons to the positively charged atoms on the target electrode and is thus changed or modulated. Its density is thus proportional to the light intensity of the original image. In this way the camera produces a continuous waveform which contains information on the brightness of the original image. This video waveform has information added to it, sync pulses, to synchronise the start of each scanning line and frame.

The video signal is transmitted and received in a similar fashion to sound transmissions. After detection and amplification it is fed to the cathode or the CRT<sup>2</sup> in the television receiver thus controlling the intensity of the electron beam. The sync pulses ensure that the beam in the CRT is in exactly the same position as the beam in the television camera. The beam is made to move sideways and progressively downwards matching line by line the scanning of the television camera. As the electron beam strikes the television screen, the phosphor coating on the screen emits light. This light varies in whiteness according to the brightness of the original image. Because the line by line build up the picture takes place so quickly, the eye sees only a complete picture of the object in front of the television camera.

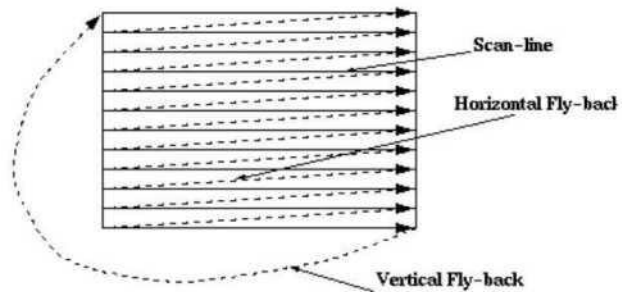

Figure 13 – Scan path of the electron beam

<sup>2</sup>CRT - Cathode Ray Tube

**photo-cathode** - a photosensitive surface that emits electrons when exposed to light or other suitable radiation; used in photo-tubes, television camera tubes, and other light-sensitive devices  
**scan** - to examine an area or a region in space point by point in an ordered sequence, as when converting a scene or image to an electric signal or when using radar or monitor an airspace for detection, navigation, or traffic control purposes

**sweep** - the steady movement of the electron beam across the screen of a cathode-ray tube, producing a steady bright line when no signal is present

**fly-back** - also called retrace - the return of the electron beam to its starting point in a cathode-ray tube after a sweep

**amplification** - the process of increasing the strength (current, voltage, or power) of a signal

## DISCUSSION QUESTIONS

1. What is the function of a lens system in a television camera?
2. What does the camera tube consist of?
3. What is the relationship between the brightness of the image and the number of electrons emitted by the photo-cathode?
4. Describe what happens when the target electrode is scanned by an electron beam.
5. What is fly-back?
6. Why is the scanning beam changed or modulated?
7. What is the density of the beam proportional to?
8. What does the camera produce in this way?
9. What does the waveform produced by the camera contain?
10. How is the video signal transmitted and received?
11. What happens when the electron beam strikes the television screen?

## 3.4 THE CATHODE RAY TUBE

The cathode ray tube (CRT) is used **in oscilloscopes, radar receivers, computers and television sets** to

produce an output display. The construction and operation of the CRT is similar in each case but the simplest type of CRT is found in oscilloscopes and will be described here. By means of a CRT, an oscilloscope not only shows the size of a signal, but also how the signal varies with time. In other words it shows the waveform of the signal.

A CRT is really a large vacuum tube valve. It has three main sections. The first section is **an electron gun** which emits a stream of electrons. The electron gun contains an electron lens which focuses the electrons into **a narrow electron beam**. Let us see how it works. A stream of electrons is released from the surface of the cathode when some heater filament heats it. The electrons are accelerated towards the screen by a set of three positively-charged cylindrical anodes. Each anode has a higher charge than the one before. As the electrons move towards the anodes, they pass through a hole in a negatively- charged metal disc. This disc is known as the control grid. By adjusting the intensity control on the oscilloscope, the charge on the grid can be varied. This allows the number of electrons reaching the screen, and therefore the brilliance or brightness of the spot on the screen, to be adjusted.

The three anodes form **the electron lens**. The oscilloscope focus control allows the voltage on the second anode to be varied and causes the stream of electrons to be focused into

a narrow beam. If the oscilloscope has an astigmatism control, it is used to vary the voltage on the third anode. This allows the shape of the spot on the screen to be adjusted to make it perfectly round.

The second section is a **deflection system**, which allows the beam to be moved vertically or horizontally. Oscilloscopes use charged metal plates to give electrostatic deflection, whereas television sets use electromagnetic coils to give electromagnetic deflection.

After leaving the electron gun, the electron beam is deflected by two pairs of parallel metal plates (Y- plates and X-plates) situated at right angles to each other. The signal to be measured is amplified by the Y-amplifier in the oscilloscope, and then applied to the first set of deflection plates, known as the Y-plates. This causes the electron beam to be deflected vertically in proportion to the magnitude of the input signal. The oscilloscope has a time base generator which produces a saw tooth wave output. This is fed to X-amplifier of the oscilloscope, and then applied to the second set of deflection plates, known as the X-plates. This causes the electron beam to be deflected on the horizontal direction in such a way that the spot moves from left to right across the screen at a steady rate. When it reaches the right side of the screen, it rapidly returns to the left side again. This allows the screen to show how the measured signal varies with time.

The last section is a **screen** with a phosphor coating. The electron beam hits the screen, making phosphor glow and causing a spot to be displayed. The colour of the spot depends on the type of phosphor used.

**cathode ray tube** - an electron-beam tube in which the electrons emitted by a hot cathode are formed by an electron gun into a narrow beam that can be focused to a small cross section of a fluorescent screen. The beam can be varied in position and intensity by internal electrostatic deflection plates or external electromagnetic deflection coils to produce a visible trace, pattern, or picture on the screen.

**oscilloscope** - a test instrument that uses a cathode-ray tube to make visible on a fluorescent screen the instantaneous values and waveforms of electrical quantities which are rapidly varying as a function of time or another quantity

**radar receiver** - a high-sensitivity radio receiver that amplifies and demodulates radar echo signals and feeds them to a radarscope or other indicator

**television set** - a receiver that converts incoming television signals into the original scenes along with the associated sounds; also called television receiver

**waveform** - the shape of a wave, as obtained by plotting a characteristic of the wave with respect to time

**electron gun** - an electron structure that produces and may control, focus, deflect, and converge one or more electron beams in an electron tube

**grid** - an electrode located between the cathode and anode of an electron tube and having one or more openings through which electrons or ions can pass under certain conditions. A grid controls the flow of electrons from cathode to anode.

**Y plate** - one of the two deflection electrodes used to deflect the electron beam vertically in an electrostatic cathode-ray tube

**X plate** - one of the two deflection electrodes used to deflect the electron beam horizontally in an electrostatic cathode-ray tube

## DISCUSSION QUESTIONS

1. What is a cathode ray tube?
2. Where is the CTR used?
3. What is the function of the CRT?
4. What does it show in oscilloscopes beside the size of the signal?
5. What can a CRT be compared to?
6. What are the three sections of a cathode ray tube?
7. What is the function of the electron gun?
8. What happens to the stream of electrons released from the surface of the cathode?
9. What is a deflection system?
10. Why is the screen coated with phosphor?

## CATHODE RAY TUBE

HOW IT WORKS		
CATHODE RAY TUBE	PLASMA	LCD
<p>A CRT monitor contains millions of tiny red, green, and blue phosphor dots that glow struck by an electron beam that travels across the screen to create a visible image.</p> <p>In a CRT monitor, the cathode is a heated filament.</p> <p>The heated filament is in a vacuum created inside a glass tube.</p> <p>The electrons are negative and the screen gives a positive charge to the screen glow.</p>	<p>The television lights up thousands of tiny dots with a high-energy beam of electrons.</p> <p>In most systems, there are three pixel colours, i.e. red, green and blue which are evenly distributed on the screen.</p> <p>By combining these colours in different proportions, the television can produce the entire colour spectrum.</p> <p>The phosphor on the screen of the plasma enhances the viewing pleasure.</p>	<p>Liquid crystal displays work by the tiny pixels<sup>3</sup> on the screen showing more than 20,000.000 colours.</p> <p>An LCD screen is a multilayered sideways sandwich.</p> <p>A fluorescent light source, known as the backlight, passes through the first of the two polarizing filters. The polarized light then passes through a layer that contains thousands of liquid crystal pixels arrayed in tiny containers called cells. The cells are, in turn, arrayed in rows across the screen; one or more cells make up one pixel.</p> <p>Electric leads around the edge of the LCD create an electric field that twists the crystal molecule, which lines the light up with the second polarizing filter and allows it to pass through it.</p>

<sup>3</sup> pixel=the smallest individual area on a screen, which together form the whole display



**CHOOSE ONE OF THE ADVANTAGES/DISADVANTAGES AND WRITE A FEW HINTS**

ADVANTAGES	DISADVANTAGES
<p><b>Cathode ray tubes</b> produce more colours. They can easily increase the monitor's brightness by reflecting the light. CRT monitors are cheaper than LCD or Plasma display. The quality of the image displayed on a CRT is superior to the LCD and Plasma monitors. CRT contrast features are considered highly excellent.</p>	<p><b>Cathode ray tubes</b> have a big back and take up space on your desk. The electromagnetic fields emitted by CRT monitors constitute a health hazard to the functioning of living cells. They also emit a small amount of X-rays and radiation which can also result in a health hazard. Since they operate at a very high voltage, system may overheat and result in an</p>
<p><b>Plasma</b> display has larger viewing angle (160° to LCD 40° and rear projection 120°). A larger audience is able to view the image reproduction. Plasma units are considerably thinner than the CRT monitors. They are either free standing or can be mounted on a ceiling or wall.</p>	<p><b>Plasma</b> display has a very short life span, i.e. around 20.000 - 30.000 hours, based on 4 hours of TV a day, plasma will last 13.7 years. As it gets older, its brightness gets dimmer. Plasma display units are considerably more expensive than CRT monitors. They are very fragile and must be handled</p>
<p><b>LCD</b> display is easier to watch and its image is perfectly sharp. It shows zero distortion at the native resolution of the panel. High peak intensity produces very bright images, best for brightly lit environments. Screens are perfectly flat, thin with a small</p>	<p><b>LCD</b> displays are considerably more expensive. After a while, some of the pixels will "die" and a discoloured spot will be seen on a black spot on the display. They have a fixed resolution display and cannot be changed. They will have a slow</p>

**4 RADIO COMMUNICATIONS**

Communicating by radio is a method of **sending** or **receiving sounds, pictures and data** through the air **by means of EM** (electromagnetic) waves.

EM waves are used for many purposes: **broadcasting** of local and national radio and TV stations, in mobile radio and telephone services, and **communicating** on a global scale through distant satellites, which act as a kind of reflector in the sky, redirecting the information which is sent to them.

Another important use of this means of communicating is in **shipping**. A ship that is in difficulty can call the nearest coast station, giving details of its situation and, if necessary, ask for help. We call this "**ship-to-shore**" radio. Radio can ensure greater safety in navigation (for example, to warn of bad weather or of hazards in the shipping lanes) and it enables large amounts of information to be sent over land or water without the support of several hundred kilometres of wires and cables. Radio networks can, therefore, be cheaper to install but often have fewer circuits than cable links. Radar systems also enable air-traffic controllers to follow and guide the flight paths of planes from take-off to landing.

The launching of **the first satellite** by the Russians in 1957 began what has become known as the "**space race**", the first stage of which culminated with the American **landing on the Moon** twelve years later. A whole range of satellites now orbit the Earth and are used for a variety of purposes.

**Low orbit satellites**, the typical height of which varies from 150 to 450 kilometres, are of little use for telecommunications for they are only **in line of sight** of each earth station for about

<sup>4</sup> implosion = inward collapse of an evacuated container, such as the glass envelope of a cathode ray tube

15 minutes. Their **rotation period** around the Earth is about one and a half hours and their main use is for remote sensing, a field in which digital processing techniques are proving especially valuable. A low orbit satellite, equipped with a multispectral scanner system (MSS), can observe the Earth in great detail providing us with extremely accurate information about agriculture, forestry, water resources and pollution patterns. It also has a multitude of applications in such as weather forecasting, environmental monitoring, geology, oceanography and cartography. There are important defence implications too, since they can be used to "spy" on the activities of a potential enemy.

**Medium altitude satellites** are used for telecommunications, especially in countries which cover a vast geographical area, like the former USSR. They fly at a typical height of 9000 to 18000 kilometres, orbiting the Earth in a period of five to twelve hours. They are in line of sight of the earth station for between two and four hours.

The most important type of satellite for telecommunications is the **geosynchronous or geostationary satellite** positioned over the Equator at a height of 35800 kilometres. Its rotation period is 24 hours, the same as the Earth's, and consequently, seen from the Earth, this type of satellite appears to remain motionless in the sky. It is within line of sight of an earth station for its entire life.

A **communication satellite** is, in essence, a microwave relay station which receives signals in a given frequency band and retransmits them at a different frequency to avoid problems of interference between the weak incoming signal and the powerful retransmitted signal. The equipment, which receives a signal, amplifies it, changes its frequency and then retransmits it, is called a transponder. A satellite can handle large amounts of traffic which it can send over vast areas of the Earth. It therefore represents a relatively cheap way of transmitting information over long distances. For countries which do not already have sophisticated cable or microwave networks the use of a satellite can be extremely beneficial as it can be used in their place.

The first satellites were seen as a way of communicating with people who lived in isolated areas of the world. As a result, earth stations began to appear in the remotest parts of the globe. The cost of satellite communication began to fall steadily and, consequently, satellites have to compete with submarine cables as a way of linking continents cheaply. With the arrival of optical fibre undersea cables, however, a more balanced division of intercontinental circuits between the two is likely.

Satellites were soon used to broadcast TV programmes "live" from one side of the Earth to the other, and then to link up computer terminals in different parts of the world. The use of digital transmission and multiplexing techniques has led to an enormous increase in the capacity of satellites.

The international organization **INTELSAT, Ltd** was created in **1964** to provide international communication services by satellite. The world's largest commercial satellite communications services provider began with **11 participating countries**. It was an intergovernmental consortium owning and managing a constellation of communications satellites providing international broadcast services. On April 6, 1965, Intelsat's first satellite, the Intelsat I (nicknamed **Early Bird**), was placed in geostationary orbit above the Atlantic Ocean by a Delta D rocket.

In **1983** it operated and owned 16 spacecraft in geosynchronous orbit representing an investment of over three billion US dollars. In 1983 it handled two third of all international telephone and data communications and transmitted virtually all "live" international television broadcasts. 109 nations are members of INTELSAT. Between 1979 and 1983 INTELSAT's traffic doubled, yet its communications charges decreased, despite a 73% rise in the worldwide cost of living index.

As of **2007**, Intelsat owns and operates a fleet of 51 communications satellites. On July 18, 2001, Intelsat became a private company, 37 years after being formed.

## DISCUSSION QUESTIONS

1. What is radio communication?
2. What are EM waves used for?
3. What is ship-to-shore radio?
4. Why is radio communication important in air-traffic?
5. What is "space race" and when did it start?
6. Why is low orbit satellite of little use for telecommunications?
7. What is low orbit satellite equipped with?
8. What can an MSS provide us with?
9. Why is MSS important in the defence of a country?
10. Where are medium altitude satellites used?
11. How long are medium altitude satellites in line of sight of the earth station?
12. Which is the most important type of satellites used for telecommunication?
13. Why?
14. What is communication satellite?
15. What is the transponder?
16. How were continents linked before satellites came into use?
17. What caused an enormous increase in the capacity of satellites?
18. What is INTELSAT?
19. When was the first communication satellite, the Early Bird, launched?
20. How many communication satellites were there in 2007

## MORE ABOUT SATELLITES

Satellites are not simply replacements for point-to-point terrestrial lines. They have several unique properties, among which the most important are:

- a 270 millisecond propagation delay caused by the distance the signal has to travel (80 000 km - 300 000 km/sec = 0.27 seconds)
- the possibility of very high bandwidths or bit rates if the user can avoid local loops by having
- an antenna on his premises, or a radio link to an earth station antenna
- the special security problems that are posed when information is broadcast through a satellite

Until recently all satellites were launched using rockets, which proved to be extremely costly as the rockets were lost in the sea a few minutes after being launched. The space shuttle, itself put into orbit by a rocket, parts of which are recovered and can be used, heralds the era of routine access to space, for one individual shuttle will be able to perform not less than 100 separate missions. Its payload is also greater than that of any previous rocket and its crew is made up not only of professional astronauts but scientists who will be able to conduct their research in the gravity-free environment of space.

## 4.1 HOW ROBOTS MAKE OUR LIVES EASIER

A **robot** is a completely self-controlled electronic, electric, or mechanical device. Many of these devices in use today do jobs that are especially **difficult for human workers**, e.g. jobs that require great strength or pose danger. Therefore, robots are particularly useful in the car industry where parts of automobile must be welded together. A welding tool used by a human worker weighs about 100 pounds or more and is difficult to handle. As mechanical supermen, robots may be called upon to do anything from moving heavy components between workstations on a factory

floor to carrying bags of cement.

**Spray painting** is another task suited for robots because robots do not need to breathe. Unlike human painters, they are unaffected by the poisonous fumes. Robots are better at this task, not because they are faster or cheaper than humans, but because they work in a place where humans cannot.

Third in the list of useful jobs for robots is **the assembly of electronic parts**. Robots shine at installing chips in printed circuits boards because of a capability that robots have and people don't. A robot, once properly programmed, will not put a chip in the wrong place. This automatic accuracy is particularly valuable in this kind of industry because locating and fixing mistakes is costly.

Earlier robots were usually blind and deaf but **newer types of robots** are fitted with video cameras and other sensing devices that can detect heat, texture, size, and sound. These robots are used in **space projects, nuclear reactor stations, and underwater exploration research**.

In their efforts to expand the range of robotic applications, researchers are looking beyond traditional designs to examine a variety of potential models from the biological world. **The industrial arm** is a classic example. Scientists have been able to model robots to imitate the vertebrate spine of a snake in order to paint the interior of automobiles. They have simulated the muscle structure and movement of an elephant's trunk in an attempt to create a robotic arm capable of lifting heavy objects. Scientists have also emulated the flexibility of an octopus where the tentacles can conform to the fragile objects of any shape and hold them with uniform, gentle pressure. A variation of this design can be used to handle animals, turn hospital patients in their beds, or lift a small child.

The challenge of equipping robots with the skills to operate independently, outside of a factory or laboratory, has taxed the ingenuity and creativity of academic, military, and industrial scientists for years. Simply put, robots hands - like robots legs, or eyes, or reasoning powers - have a long way to go before they can approach what biological evolution has achieved over the course of hundreds of millions of years. Much more will have to happen in laboratories around the world before robots can be compared to nature's handiwork.

In the meantime, the robotics revolution is already beginning to change the kind of work that people do. The boring and dangerous jobs are now assumed by robots. In the third millennium, more and more humans will be required for tasks that machines cannot do. There are some industrialists who hope that all their employees will be knowledge workers, no longer standing on assembly lines but rather sitting at desks and computer terminals to deal with information. These changes are already on the way, and their pace accelerates every year.

Finally, **their use in medicine** has saved many lives due to their accuracy and reliability that have outcome the surgeons in numerous applications. Some surgical procedures using robots are less aggressive, "spill" less blood, and the possibility for human errors is much smaller.

## DISCUSSION QUESTIONS

1. What do you think about robotics revolution in general?
2. What kind of jobs can robots do instead of men?
3. Why are they particularly useful in car industry?
4. What are the advantages of robots over people when spraying paint is considered?
5. Why are robots preferred on assembly lines for electronic parts?
6. What is the difference between earlier and newer types of robots?
7. What are these new types of robots used for?
8. What kind of robots have the scientists been trying to create?
9. What do industrialists hope for in the third millennium?
10. In your opinion what are the advantages and/or disadvantages of robotics revolution?

## 11. Why are robots used in medicine?

### **TRANSLATE INTO UKRAINIAN**

#### **ROBOT EYE FOR SURGERY**

Laparoscopy is a procedure in which a camera is pushed through a small hole in the abdominal wall. It allows a surgeon to operate by television, with instruments inserted through a second hole. The small size of the incision reduces the trauma for patients and speeds up recovery. Until recently, the procedure has required the presence of a second doctor to guide the camera for the surgeon.

A new development now facilitates this procedure. A robot manoeuvres the camera in response to the surgeon's head. Four tiny transmitters, worn on a headband, send radio signals to a base unit. As the surgeon moves his head left or right, up or down, forwards or backwards, the robot causes the camera to track his movements, enabling him to view the exact area he wishes to see.

#### **ROBOT SURGERY FOR EYE**

Techniques derived from virtual reality will soon allow surgeons to feel as well as see the inside of the eye during an operation. During the operation, the surgeon manipulates a set of controls known as the master. These are connected through a high-performance computer to the robot. The robot's limbs move in exactly, except that the movements can be scaled down as much as a thousand times, thus eliminating hand tremor and reducing damage to the eye.

The computer also creates a three-dimensional view of the inside of the eye, which the surgeon can see wearing a virtual reality helmet and "feel" via a sensory feedback system, which emulates the forces generated by cutting with a surgical tool.

#### **ROBOT'S "HISTORY"**

- in 270 BC an ancient Greek engineer named Ctesibus made organs and water clocks with movable figures.
- 1818 - Mary Shelley wrote "Frankenstein" which was about a frightening artificial life form created by Dr. Frankenstein.
- 1921 - The term "robot" was first used in a play called "R.U.R." or "Rossum's Universal Robots" by the Czech writer Karel Capek. The plot was simple: man makes robot then robot kills man!
- 1941 - Science fiction writer Isaac Asimov first used the word "robotics" to describe the technology of robots and predicted the rise of a powerful robot industry.
- 1942 - Asimov wrote "Runaround", a story about robots which contained the "Three Laws of Robotics":
  - 1) A robot may not injure a human, or, through in action, allow a human being to come to harm.
  - 2) A robot must obey the orders by human beings except where such orders would conflict with the First Law.
  - 3) A robot must protect its own existence as long as such protection does not conflict with the First or Second Law.
- 1948 - "Cybernetics", an influence on artificial intelligence research was published by Norbert Wiener
- 1956 - George Devol and Joseph Engelberger formed the world's first robot company.
- 1959 - Computer-assisted manufacturing was demonstrated at the Servomechanisms Lab at MIT.
- 1961 - The first industrial robot was online in a General Motors automobile factory in New Jersey. It was called UNIMATE.
- 1963 - The first artificial robotic arm to be controlled by a computer was designed. The Rancho Arm was designed as a tool for the handicapped and its six joints gave it the

flexibility of a human arm.

- 1965 - DENDRAL was the first expert system or program designed to execute the accumulated knowledge of subject experts.
- 1968 - The octopus-like Tentacle Arm was developed by Marvin Minsky.
- 1969 - The Stanford Arm was the first electrically powered, computer-controlled robot arm.
- 1970 - Shakey was introduced as the first mobile robot controlled by artificial intelligence. It was produced by SRI International.
- 1974 - A robotic arm (the Silver Arm) that performed small-parts assembly using feedback from touch and pressure sensors was designed.
- 1979 - The Stanford Cart crossed a chair-filled room without human assistance. The cart had a TV camera mounted on a rail which took pictures from multiple angles and relayed them to a computer. The computer analyzed the distance between the cart and the obstacles.

## 4.2 CIRCUIT BREAKERS, FUSES AND SWITCHES

A **circuit breaker** is an electromagnetic device that opens the circuit automatically when the current exceeds a predetermined value. It can be reset operating a lever or by other means. A **fuse** is a protective device containing a short length of special wire that melts when the current through it exceeds the rated value for a definite period of time. A fuse is inserted in series with the circuit being protected, so it opens the circuit automatically during a serious overload. A **switch** is a manually, or mechanically, electrically or electronically actuated device for making, breaking, or changing the connections in an electric circuits. Their function, to put it simple, is to protect the circuit in which they are built from possible damages. They are designed to interrupt excess current that can overload the electrical wires, and they cut off the circuit whenever the current jumps above a safe level.

A circuit breaker, unlike a fuse, which operates once and then has to be replaced, can be reset (either manually or automatically) to resume normal operation. The choice of a proper circuit breaker depends on the particular application, i.e. it may be a small device used for protecting individual household appliance, or a large switchgear designed to protect high voltage circuits feeding an entire city. **A circuit breaker is required to**

- withstand the maximum voltage stress,
- carry rated current continuously without damage,
- have sufficient interrupting capacity,
- be suitable for operation in the intended environment
- provide the protective function or protective and control functions if needed.

There are many types of switches available for electric circuits. All **switches** perform the same basic function of opening or closing circuits. The type used in a given application is often a matter of style and/or convenience of operation. When the switching requirements are complex, the choice narrows to the rotary switch. On the other hand, simple switches, such as toggles, slides, rockers, levers etc, usually control only one or two circuit paths. Some switches are constructed so that they always return to the same position when released by the operator. There are also safety switches which look similar to circuit breakers, but they provide extra protection from electric shock. Safety switches monitor the flow of electricity and if any irregularity is detected, the electricity supply is immediately cut off.

**Fuses** have the advantage of often being less expensive and simpler than a circuit breaker for similar rating. However, a blown fuse must be replaced with a new device while a circuit breaker is simply reset. While circuit breakers must be maintained on an annual basis to ensure their mechanical operation, this is not the case with fuses; no mechanical operation is required for

the fuse to operate under fault conditions. Old electrical consumer units were fitted with so called Swiss electric fuses (6 to 10 A) and are still in use in some older European buildings. Modern consumer units contain magnetic circuit breakers instead of fuses. Fuses are often characterized as "fast-blow" or "slow-blow" according to the time they take to respond to an overcurrent condition. A fuse also has a rated interrupting capacity, also called breaking capacity, which is the maximum current the fuse can safely interrupt.

### DISCUSSION QUESTIONS

1. What is the function of circuit breakers, fuses, and switches?
2. What is the difference between a circuit breaker and a fuse when they have to resume normal operation?
3. What are the requirements of a circuit breaker?
4. What are the types of simple switches?
5. How many circuit paths do simple switches usually control?
6. What is the difference between safety switches and ordinary simple switches?
7. What do safety switches monitor?
8. What happens if any irregularity is detected within the circuit?
9. What are the advantages of fuses over circuit breaker?
10. What is rated interrupting capacity?

MAKE SENTENCES CONNECTING As and Bs:

A	B
1. Electricity is defined by three major attributes,	1. it helps to know how household electricity works.
2. To understand circuit breakers,	2. that makes electric charge move.
3. Voltage is the "pressure"	3. the charge moves through the conductor
4. When the fuse carries an excess of current over its rated capacity,	4. the most important safety mechanisms in our home.
5. Current is the rate at which	5. you can't change one without changing another.
6. The circuit breaker is one of	6. the connections in an electric circuit
7. Voltage, current and resistance are all interrelated,	7. be reset.
8. Switches are devices which make, break, or change	8. inserted in series with a circuit.
9. Circuit breakers can	9. voltage, current and resistance.
10. A fuse consists of a strip of wire or metal	10. it burns out.

## TRANSLATE INTO UKRAINIAN

A switch is a device that opens or closes a circuit. It is a device that causes the operating conditions of a circuit to change between discrete specified levels. It selects from two or more components, parts, or circuits the desired element for a particular mode of operation. In general, a switch consists of a mechanical device, such as a circuit breaker, or a solid state device, such as a transistor, Schottky diode, or field-effect transistor.

A circuit breaker is a device such as a contactor, switch, or tripping device that is used to make or break a circuit under normal or fault conditions. An unwanted arc is often produced as the circuit breaker operates and this can be minimized using magnetic blow out device. This device is fitted to the circuit breaker and produces a magnetic field in the neighbourhood of the arc, thus causing the path length of the arc to increase and thereby extinguishing it rapidly. When used for fault conditions an automatic break and manual make system is commonly used.

A fuse consists of a short length of easily fusible wire that is used to protect electric circuits or devices by melting ("blowing") at a specific current and thus breaking the circuit. The fuse current rating is the maximum value of the current that the fuse will conduct without melting. The frequency and voltage at which a fuse is designed to operate are specified by the fuse frequency rating and fuse voltage rating. The fuse characteristic is the relation between the current through the fuse and the time taken for the fuse to operate.

## 4.3 POWER ENGINEERING

Power engineering deals with the **generation, transmission and distribution** of electricity. The design of a range of related devices is also an important category in the power engineering process. These devices are **transformers, electric generators, electric motors and power electronics**. But first, let us see how electricity is generated.

Power stations, generating units or power plants are facilities which generate electric power. The center of nearly all power stations is a generator, a rotating machine that converts mechanical energy into electrical energy. The energy sources, **renewable and non-renewable**, harnessed to turn the generator vary from water, fossil fuel, nuclear reaction, wind or solar energy. Each of them has some unique aspects, but they all operate on the similar principle of converting some form of fuel into heat energy, then mechanical energy and finally electrical energy.

**GENERATION** - When fuel, e.g. natural gas, coal or oil is burned in a boiler, the heat is used to produce steam under pressure. The steam is piped to a turbine. The steam strikes the blades of the turbine and spins them, revolving the turbine shaft. The turbine shaft turns the electromagnet of the generator, changing the mechanical energy from the turbine into electrical energy. The electric energy then takes the form of alternating current (AC) and direct current (DC). The hydro electric power plant consists of a water turbine

**TRANSMISSION** - Once electricity is produced, it runs from the power plant through wires to step up transformer. The transformer raises the pressure so it can travel long distances. Transformers play very important role in power transmission because they allow power to be converted to (step up transformers) and from (step down transformers) higher voltages. Higher voltages, on the other hand, are important because higher voltages suffer less power loss during transmission. Electricity is usually transmitted over long distance through overhead power transmission lines. Underground power transmission is used only in densely populated areas such as large cities because of the high cost of installation and maintenance and because the power losses increase dramatically compared with overhead transmission.

**DISTRIBUTION** - There is an inherent problem about electrical energy, i.e. it is not



storable, except in batteries. Therefore, it has to be transmitted and distributed to end users - homes, industry or business. After coming off the transmission grid, electricity is stepped down to the distribution grid. This conversion from transmission to distribution occurs in a power substation. In order to step down the high voltages used for transmission, power substations use transformers which step down transmission voltages to distribution voltages, they have a bus that can split the distribution power off in multiple directions, or they have circuit breakers and switches which disconnect the substation from the transmission grid when necessary.

**TERMS AND DEFINITIONS transformer** - a component that consists of two or more coils which are coupled together by magnetic induction; it is used to transfer electric energy from one or more circuits to one or more other circuits without change in frequency but usually with changed values of voltage and current

**electric motor** - a machine that converts electric energy into mechanical energy by utilizing forces exerted by magnetic fields produced by current flow through conductors

**electronics** - the branch of science or technology that deals with electron devices, including electron tubes, magnetic amplifiers, transistors, and other devices that do the work of electron tubes in controlling the flow of electricity in a vacuum, gas, liquid, semiconductor, conductor or superconductor power electronics - the technology associated with the efficient conversion, control and conditioning of electric power by static means from its available input form into the desired electrical output form **renewable energy sources** - sources that are in constant supply over time such as sun, wind, water, biomass and earth, i.e. heat from deep within the earth, called "geothermal energy" **non-renewable energy sources** - fossil fuels such as oil, natural gas and coal and nuclear fuel

**principle of the conversion of energy** - energy cannot be created or destroyed, but it may be converted from one form into the other

## DISCUSSION QUESTIONS

1. What does power engineering deal with?
2. Where is electric power generated?
3. What is the main device in power stations?
4. What is a generator?
5. What energy sources are used to turn generators?
6. What is the difference between renewable and non-renewable energy sources?
7. What is the principle on which all power stations operate?
8. Describe the process of the generation of the electric energy.
9. What are step up and step down transformers used for?
10. Why does voltage have to be stepped up during transmission?
11. What kind of transmission lines is there and what is the difference between them?
12. What is the inherent problem about electricity?
13. What do power substations use to step down the high voltages used for transmission?

## **TRANSLATE INTO UKRAINIAN**

### **ENERGY CRISIS**

A word about the energy crisis: the world's supply of petroleum was created over millions of years ago and cannot be replaced or renewed in our time. Estimates vary on how long the supply will last but according to some experts it may be not much more than thirty years at the present rate of consumption. Automobiles, diesels, and jets use enormous amounts of fuel derived from petroleum so do households and power plants that produce electricity. Petroleum is also the basis for petrochemical products including many of today's plastics, fertilizers, and insecticides.

Naturally, there is a growing interest in engines that do not use petroleum as fuel. Some power plants are already converting from oil to coal, but while coal is in much greater supply than petroleum, it is another non-renewable energy source, which will eventually be exhausted. Experiments are under way to harness such energy sources as the wind, the tides, and the sun. Nuclear fusion - the release of energy when atoms join - is being explored as a safer alternative to nuclear fission with its hazardous by-products of radioactive wastes that pose a serious threat to the environment and to human life. The difficulty with fusion is that it requires an enormously high degree of heat to start the reaction. To date it has not been possible to generate that much heat even under laboratory conditions.

### **ADVANTAGES AND DISADVANTAGES OF WIND ENERGY**

There are many great advantages of wind energy, such as its availability. The wind is available around the globe and it will exist till the time the sun exists. Wind energy is a renewable source of energy, it is widely distributed, it is cheap and does not pollute the air like power plants that rely on combustion of fossil fuels. Wind turbines do not produce atmospheric emissions that cause acid rain or greenhouse gasses.

Wind energy is the fastest-growing energy source in the world and it may be the answer to the globe's question of energy in the face of rising petroleum and gas prices. It is one of the lowest-priced renewable energy technologies available today - the cost of producing wind energy has come down by at least eighty percent since the eighties.

Wind energy could help reducing food production prices since wind turbines can be built on farms or ranches, thus benefiting the economy in rural areas without any effect whatsoever on the land necessary for their installation.

There are, however, some disadvantages. First, the technology requires a higher initial investment than fossil-fueled generators, wind can never be predicted and it does not blow when electricity is needed. To create a proper amount of wind energy, a large number of turbines have to be built to meet the timing of electricity demands. Although, wind power is non-polluting, the turbines may create a lot of noise, which indirectly contributes to noise pollution. Most potential farms which would use wind energy are often located in remote locations. Since wind energy cannot be stored unless batteries are used, knowledge of the weather and wind conditions on long term basis is required.

POWER" CROSSWORD PUZZLE

1	2					3		4		
										5
			6							
			7							
	8									
				9						

**Across**

- 1 the capacity of electric generator is measured in
- 7 the rate of electricity usage is usually measured in hour
- 8 in most countries, \_ is still the largest primary energy source for electricity
- 9 in electricity generation, steam, hot gas or other forms of energy turns the blades of a

**Down**

- 2 in converting a primary energy source into electricity, some percentage of the initial heat energy is lost, and the remaining percentage measures the of the power plant
- 3 before electricity gets up on the wire to be transmitted, it goes through a to step up the voltage
- 4 electricity is not a primary source of energy; it is a source because it is generated from primary sources of energy
- 5 a generator uses \_\_\_ and coils of wire to produce electricity
- 6 \_\_\_ demand is the time when many electricity customers want to use electricity at the same time

**PUT A "+" SIGN FOR THE USES OF EACH RENEWABLE SOURCE**

	heat	electricity	vehicle fuel
water power			
biomass energy			
wind power			
solar energy			
geothermal energy			

**5 TELECOMMUNICATIONS**

Telecommunications is a general term used for a wide spectrum of technologies that send information over distances. **Tele-** is a prefix meaning "**from a distance**". Telecommunication is any transmission, emission, or reception of signals, writing, images, sounds, or intelligence of any nature by wire, radio, visual, or other electromagnetic systems. It is the assisted transmission of signals over a distance for the purpose of communication. It includes all telephony technologies, such as mobile phones, land lines, satellite phones, voice over Internet protocol as well as radio, television and networks.

Today, telecommunications is associated with modern technologies. Nevertheless, the use of smoke signals used by the American Indians is a kind of visual telegraph - it is an ancient and primitive form of telecommunication. There were others, of course, but let us focus on the modern term, the telecommunications of today. However, some historical data first!

In the **19th century**, with the numerous discoveries in the field of electricity, telecommunications devices became more sophisticated. Those were telegraph, Morse code, signal lamps, a heliograph. In the **20th century**, telecommunications reached beyond our planet. In June 1969, the world watched and listened as astronauts walked on the moon. Twenty years later the pictures of Neptune sent from the Voyager 2 travelled over three billion miles (4.8 billion km) to reach us in only a few hours. People today have multiple ways to see and hear what is going on almost anywhere in the world in real time. Satellite technology, television, telephone, the Internet - they all keep the globe connected either by voices or pictures.

A telecommunication system consists of **three basic elements, i.e. a transmitter, information and a signal**. For example, in a radio broadcast the broadcast tower is the transmitter, free space is the transmission medium and the radio is the receiver. Telecommunication systems are often two-way,

i. e. a single device acts as both a transmitter and a receiver or transceiver. A mobile phone is an example of a transceiver.

The importance of telecommunication services in the infrastructure of a country is universally recognized. But what is their internal order of importance? The late **Arthur C. Clarke**, author of 2001...A Space Odyssey and the first person to conceive the idea of geosynchronous satellites, tried to answer the question in a recent address. He listed a number of services in the following order:

- i. the telephone
- ii. radio and TV
- iii. telex
- iv. data networks.

"A reliable telephone system must surely have the first priority," said Clarke, "for it affects every aspect of life ... personal, business, government. It will be a long time, but not as long as you think, before everybody has a telephone. But with a telephone in every village

we can have the next best thing".

He pointed out that with the introduction of International Direct Dialling in recent years, the power of the state to control news was broken. Private individuals can now speak to each other across frontiers.

Clarke placed radio next in his list of priorities because he considered it central to spreading information and establishing a national consciousness. He considered that radio was nowhere near the end of its development, an opinion which is confirmed by the rapid growth and enormous success of cellular radio. He saw at least two major developments in the field of radio technology: the use of built-in solar cells to replace batteries and the use of direct broadcasting satellites to give perfect signal reception all over the world. It is for us to see how right he was!

**TERMS AND DEFINITIONS** **point-to-point communication** - communication between one transmitter and one receiver

**broadcast communication** - radio communication between one powerful transmitter and numerous receivers

**analog(ue) signal** - the signal is varied continuously with respect to the information; the information in the signal is degraded by the noise

**digital signal** - the information is encoded as a set of discrete values (ones and zeros); the information remains intact unless the noise exceeds a certain threshold

**network** - transmitters, receivers or transceivers communicating with each other

**channel** - a division in a transmission medium resulting in the possibility of sending multiple streams of information

**modulation** - the shaping of a signal to convey information **DISCUSSION QUESTIONS**

1. What does the term telecommunication mean?
2. What is telecommunication?
3. What technologies does telecommunication include?
4. When did the fast growth of telecommunications start?
5. Why?
6. What revolutionary achievements concerning telecommunications happened in the 20th century?
7. What does every telecommunication system consist of?
8. What is a transceiver?
9. How did Arthur Clarke list the telecommunication services?
10. Explain the order of the services according to Clarke.

## **TRANSLATE INTO UKRAINIAN**

### SINCE THE BIRTH OF THE TELEPHONE

Since the birth of the telephone, the world telecommunications network has evolved in size, slowly at first and then with astonishing speed, and in the techniques used to transmit information. The development has, however, been very uneven for, by 1983, three-quarters of the total number of telephone sets had been installed in just nine countries. These are the USA (180 million), Japan (59 million), West Germany (28 million), the UK and France (27 million each), Italy (19 million), Canada (16 million), Spain (13 million) and Australia (8 million).

The eastern block countries are not included in these figures, but at the beginning of 1982 the USSR is estimated to have had 25 million sets, East Germany, Poland and Czechoslovakia just over 3 million each. In 1982 Croatia had 443,000 telephone sets and by the end of 1999, there were 1.450,000 sets. When "World Communications Year: 1983" was organized by the ITU (International

Telecommunication Union), the following statement was heard:

"Communications, which come immediately after food, housing and energy in the list of things which are indispensable for the survival of Humanity, make up the nervous system of today's world and constantly remind us that Humanity is one."

In 2007, the situation was drastically different. It is hard to believe, but Europe had more mobile phones than people! For example, Luxembourg had 158 mobile subscriptions per 100 people, and the number is still growing. The total number of mobile phone subscribers in the world was estimated at 3.3 billion by November 2007, thus reaching an equivalent of over half the planet's population. In 2011, the number of cell phone subscribers across the globe hit 5,6 billion!

No doubt, the famous statement uttered in 1983 during "World Communication Year 1983" has already got its confirmation.

### SCRAMBLED SENTENCES

(begin the sentence with the word in a capital letter):

1. Telecommunication, point-to-point communication, and, one transmitter, is called, because, over a phone line, it is, between, one receiver
2. The function, is, the signal, of the transmission medium, to carry
3. converts, information, it, A transmitter, takes, to a signal, and
4. multiple streams of, a transmission medium, so that, A channel, it can be used, is, information, a division in, to send
5. analogue, can be, digital, Signals, either, or
6. through radio broadcasts, broadcast communication, Telecommunication, between, is called, and, because, numerous receivers, it is, one powerful transmitter
7. the signal, with respect to, an analogue signal, continuously, the information, In, is varied
8. is, that, receivers, with each other, or transceivers, a collection of transmitters, communicate, A network
9. the information, In, discrete values, a digital signal, as a set of, is encoded

## 5.1 OPTICAL FIBERS

Optical fiber can be used as **a medium for telecommunication and networking** particularly for long-distance communications (data, voice & video). Optical fibers convert electrical pulses into pulses of light. Light impulses are transmitted through the optical fibers and re-converted into electrical impulses at their destination.

They are **thinner than a human hair** and are made of glass or plastic. They are designed to guide light along its length and they work even if they are bent around corners, laid underground or on the ocean floor. Fiber-optic communications are used not only to transmit over longer distances but due to their higher data rates they are more useful than other forms of communications. Signals travel along them with **less degradation**, and they are **immune to electromagnetic interference**.

Most fibers are made from **silica**, which is very cheap and occurs in several different natural forms, e.g. quartz and common sand. They are relatively cheap, flexible and

lightweight. A 500 m of optical fibers weighs about 25 kg, while a coaxial cable of the same length weighs 5 tons.

However, joining lengths of optical fiber is more complex than joining electric wire or cable because the ends of the fibers must be carefully **spliced**<sup>16</sup> together. Nevertheless, they are less expensive than copper wires and, unlike electrical signals in copper wires, light signals from one fiber do not interfere with those of other fibers in the same cable.

In spite of high investment cost, the need for more expensive optical transmitter and receivers, their cost is much more economic than old coaxial cables and communication systems are now unthinkable without fiber optics. Transmitter and receivers (laser and photodiodes) turn out cheaper than electric circuitry as their capacity is much superior. The cost of regeneration in electric long distance transmission systems is completely impractical for modern communications. Optical fibers cannot carry electric power to operate terminal devices.

Optical fibers are widely used in **illumination applications**, e.g. as light guides in **medical imaging** to view objects through a small hole (bronchoscopes, endoscopes, laparoscopes), **mechanical imaging** to inspect anything hard to reach (mechanical welds in pipes and engines, jet engine interiors), in some buildings they are used **to route sunlight** from the roof to other parts of the building, optical fiber illumination is also used for **decorative applications** (signs, art, artificial Christmas trees), etc.

Due to the above advantages, fiber optics can be seen in many industries, particularly in telecommunications and computer networks. It has **an enormous bandwidth**, a bandwidth which is practically unlimited. Just one more remark - no fiber, no Internet!

5

## TRANSLATE INTO UKRAINIAN

### TRANSMISSION CAPACITY OF OPTICAL FIBERS

Since 1970s, the transmission capacity of optical fibers has been enormously increased. The rise of available transmission bandwidth per fiber is even significantly faster than, e.g. the increase of storage capacity of electronic memory chips, or the increase of computation power of microprocessors.

The transmission capacity of a fiber is strongly dependent on the fiber length. The longer a fiber is, the more detrimental certain effects such intermodal or chromatic dispersion are, and the lower is the achievable transmission rate.

For short distances of a few hundred meters or less, e.g. within storage area networks, it is often more convenient to utilize multimode fibers, as these are cheaper to install. For example, due to their large core areas, they are easier to splice.

Single-mode fibers are typically used for longer distances of a few kilometers or more. Current commercial telecom systems typically transmit 2.5 or 10 Gbit per second (Gbit/s) per data channel over distances of ten kilometres or more. Future systems may use higher data rates per channel of 40 Gbit/s or even 160 Gbit/s, but currently the required total capacity is usually obtained by transmitting many channels with slightly different wavelengths through fibers; this is called wavelength division multiplexing (WDM). Total data rates can be several terabits<sup>6</sup> per second, sufficient for transmitting many millions of telephone channels simultaneously. Even this capacity does by far not reach the physical limit of an optical fiber. In addition, note that a fiber-optic cable can contain multiple fibers. In conclusion, there has to be no concern that technical limitations to fiber-optic data transmission could become severe in the foreseeable future. To the

---

<sup>5</sup> splice = join the ends of two fibers by twisting of by fusing them with an electric arc

<sup>6</sup> a terabit = one trillion bits; used for measuring the amount of data that is transferred in a second between two telecommunication points or within network devices.

contrary, the fact that data transmission capacities can evolve faster than, e.g. data storage and computational power, inspired some people to predict that any transmission limitations will soon become obsolete, and large computation and storage facilities within high capacity data networks will be extensively used, in a similar way as it has become common to use electrical power from many power stations within a large power grid. Such developments may be more severely limited by software and security issues than by the limitations of data transmission.

## 5.2 NIKOLA TESLA - THE GENIUS WHO LIT THE WORLD

The Law of conservation of energy and at the same time the core of Tesla's AC power system says: **Energy cannot be created or destroyed but it can be changed**. He was the first to successfully harness the **mechanical energy of flowing water**, change it into electrical energy, and distribute it to distant homes and industries. His idea was realized at Niagara Falls at the end of the nineteenth century and this revolutionary model set the standard for hydroelectric power, as we know it today.

Since his childhood, Tesla himself dreamed of harnessing the power of the great natural wonder. In **1887 Tesla** obtained **American patents** for his new motor that produced **alternating current**. When in **1893** George **Westinghouse** was awarded **the contract to create the powerhouse**, his dream became a reality. In spite of Edison's and Lord Kelvin's strong opposition to AC, after attending the Chicago Exposition, **Lord Kelvin**, the famous British physicist and his commission asked Westinghouse to use alternating current to harness the power of the falls. And Westinghouse called Nikola Tesla. The rest is history! Although the Niagara Falls Power project was considered an adventure of pure technological optimism, after a five-year nightmare of doubt and financial crises, the project approached completion. Tesla had not doubted the results for a moment. The investors, however, were not at all sure the system would work. Nevertheless, Niagara Falls was the final victory of Tesla's alternating current over Edison's direct current electricity.

Unfortunately, **the War of the Currents**, as the battle between promoters of DC and AC was called, exhausted both the Westinghouse and General Electric corporations morally and financially. Their opponents, rich and influential managers<sup>7</sup> who wanted to bring all US hydroelectric power under their control, went on manipulating stock market trying to starve out Westinghouse and buy the Tesla patents. But, thanks in part to Tesla, this did not happen. Grateful to George Westinghouse, who had believed in his invention, Tesla tore up the contract saving the Westinghouse Electric Company for future triumphs. He was convinced that even greater inventions lay ahead, although he himself, besides sharing the glory, did not enjoy financial aspects of his great work.

**The Niagara Falls Power Project** can be described in a few words now. First, the river water just above the falls is diverted into 140-foot-long artificial shaft, where water pushes the propeller, like blades of a turbine. The result is that the kinetic energy of the moving water is transformed into mechanical energy. The mechanical energy is changed to electrical energy. The output is polyphase alternating current. The further steps are the same in Tesla's time as they are today, i.e. high voltage transmission over long-distance power lines to substations, step-down transformers which decrease the voltage delivering 220 volts to homes and up 480 volts to industrial plants.

The Niagara Project demonstrated the superiority of transmitting power with electricity rather than by mechanical means, as well as the transmission superiority at that time of alternating current over direct current. Niagara set a contemporary standard for generator size, and was the first large system supplying electricity from one circuit for multiple end-uses such as railway, lightning, and power.

---

<sup>7</sup> T. A. Edison, R. Barons, J.P. Morgan



After the success of Niagara, Tesla resumed his experiments focusing all his attention to the exploration of high frequency electricity. His impressive achievements and patents numbering 700 in the USA and Europe brought him the name of "the genius who lit the world".

Let us return to the time before a meeting of the Royal Society in London in 1892, when Lord Rayleigh declared that Tesla possessed a great gift for electrical discovery and in 1896, at the Franklin Institute in Philadelphia, Lord Kelvin said, "Tesla has contributed more to electric science than any man up to his time." In 1919, Thomas Commerford Martin, the third president of the AIEE<sup>8</sup>, who edited and published a remarkable collection of Tesla's contemporary lectures in 1893, wrote "Tesla's influence may truly be said to have marked an epoch in the progress of electrical science. Very little data, however, has been procurable that is descriptive of his later researches, and more is the pity from the historical standpoint. Tesla has not finished. The world waits expectantly for each fresh touch of his vitalizing thought upon the big electrical problem of the age."

No doubt, Tesla deserved all these words of praise, but there are still some facts about him which are not universally known. After all these years, it is now known that he was nominated for an undivided Nobel prize in physics in 1937. Tesla's nominator, Felix Ehernhaft, of Vienna, had previously nominated Albert Einstein for the Nobel Prize. Most electrical engineers are unaware that, as late as 1943, Tesla, and not Marconi, was recognized by the US Supreme Court as having priority in the invention of "radio". Even fewer computer scientists know that, when certain computer manufacturers attempted to patent digital gates after World War II, the US Patent Office asserted Tesla's priority in the electrical implementation of logic gates for secure communications, control systems, and robotics.

Just one more statement by Charles E. Scott, past president of the AIEE, published in 1943 in Electrical Engineering - "The evolution of electric power from discovery of Faraday in 1831 to the initial great installation of the Tesla polyphase system in 1896 (at Niagara Falls) is undoubtedly the most tremendous event in ALL engineering history."

His genius and his ideas are still alive. In the years to come, we will probably witness the realization of his lifelong obsession - the wireless transmission of energy.

## DISCUSSION

Although Nikola Tesla is considered the father of our modern technological age and one of the most mysterious and controversial scientists in history, many of his discoveries went virtually unnoticed for nearly a century. His contributions to science and technology include the invention of radio, television, radio-astronomy, remote control and robotics, radar, medical x-ray and the wireless transmission of electricity. Encyclopedia Britannica lists Nikola Tesla as one of the top ten most fascinating people in history. So why is he virtually unknown to the general public? Who and why has been hiding his ideas and inventions?

## 5.3 NANOTECHNOLOGY

Manufactured products are made from atoms. The properties of those products depend on how those atoms are arranged. If we **rearrange the atoms** in coal, we can make **diamond**. If we rearrange the atoms in **sand** (and add a few other trace elements), we can make computer **chips**. If we rearrange the atoms in dirt, water and air, we can make potatoes. Isn't it black magic? Are the medieval witches back? No, they say. It is **nanotechnology**! And it refers to a field of applied science and technology in order to control matter on the atomic and molecular scale. The "size" is

---

<sup>8</sup> AIEE = American Institute of Electrical Engineers

generally 100 nanometres<sup>9</sup> or smaller resulting in the fabrication of devices with critical dimensions that lie within that size range. That small?

Today's manufacturing methods are very crude at the molecular level. Casting, grinding, milling and even lithography move atoms in great thundering statistical herds. It's like trying to make things out of LEGO blocks with boxing gloves on your hands. Yes, you can push the LEGO blocks into great heaps and pile them up, but you can't really snap them together the way you'd like.

In the future, **nanotechnology** will let us take off the boxing gloves. We'll be able to snap together the fundamental building blocks of nature easily, inexpensively and in most of the ways permitted by the laws of physics. This will be essential if we are to continue the revolution in computer hardware beyond about the next decade, and will also let us fabricate an entire new generation of products that are cleaner, stronger, lighter, and more precise.

It's worth pointing out that the word "**nanotechnology**" has become very popular and is used to describe many types of research where the characteristic dimensions are less than about 1,000 nanometres. For example, continued improvements in lithography have resulted in line widths that are less than one micron: this work is often called "nanotechnology." Sub-micron lithography is clearly very valuable (ask anyone who uses a computer!) but it is equally clear that lithography will not let us build semiconductor devices in which individual dopant atoms are located at specific lattice sites. Many of the exponentially improving trends in computer hardware capability have remained steady for the last 50 years. There is fairly widespread belief that these trends are likely to continue for at least another several years, but then lithography starts to reach its fundamental limits.

Nanotechnology is a highly multidisciplinary field, from applied physics, materials science, interface and colloid science, device physics, supramolecular chemistry, self-replicating machines and robotics, chemical engineering, mechanical engineering to biological engineering and electrical engineering.

Examples of nanotechnology in modern use are the manufacture of polymers based on molecular structure, and the design of computer chip layouts based on surface science. Despite the great promises of numerous nanotechnologies, real commercial applications have mainly used the advantages of colloidal nanoparticles in bulk form, such as suntan lotion, cosmetics, protective coatings, drug delivery and stain resistant clothing.

The idea of manipulating and positioning individual atoms and molecules is still new and takes some getting used to. However, as **Feynman** said in a classic talk in 1959: "**The principles of physics, as far as I can see, do not speak against the possibility of manoeuvring things atom by atom.**" We need to apply at the molecular scale the concept that has demonstrated its effectiveness at the macroscopic scale: **making parts go where we want by putting them where we want!**

The requirement for low cost creates an interest in self replicating manufacturing systems, studied by **von Neumann** in the 1940's. These systems are able both to make copies of themselves and to manufacture useful products. If we can design and build one such system the manufacturing costs for more such systems and the products they make (assuming they can make copies of themselves in some reasonably inexpensive environment) will be very low.

Before ending this almost science fiction story, let's just mention a few applications of nanotechnology. In medicine, nanotechnology is used in diagnostics, drug delivery and tissue engineering. Energy - reduction of energy consumption, increasing the efficiency of energy production, the use of more environmentally friendly energy systems, recycling of batteries. Information and communication - novel semiconductor devices, displays, quantum computers. Heavy industry - aerospace, refineries, vehicle manufacturers. Consumer goods - foods,

---

<sup>9</sup> nano = one billionth, prefix meaning  $10^{-9}$ ; the comparative size of a nanometer to a meter is the same as that of a marble to the size of the Earth!

household, optics, textiles, cosmetics.

The above list speaks for itself! Nevertheless, one important question arises: Will it be possible to rearrange atoms in humans in order to get good and normal people? It would be a much greater achievement than to make potatoes. Potatoes can always be planted.

## DISCUSSION QUESTIONS

WRITE DOWN THE ANSWERS AND DISCUSS THEM WITH YOUR COLLEAGUES

1. What is your opinion of nanotechnology?
2. Which of the above nanotechnology aspects do you find most interesting and important?
3. Explain why.
4. Do you have some knowledge about other achievements in nanotechnology which have not been mentioned in the text?

## PART 2

### 1 HOW TO WRITE A JOB APPLICATION

Even before they graduate, students start thinking about their future employment and one of the first things they have to do is to write and submit a job application and a CV<sup>10</sup> or resume.

In different countries, different conventions apply to the process of **job application** and **interviews**. However, a CV or resume contains all the unchanging information about the student, i.e. **education, background** and **work experience**. This usually accompanies a **letter of application**, which in some countries is expected to be hand-written, not word-processed. A supplementary information sheet containing information relevant to this particular job may also be required, though this is not used in some countries. In some companies applicants are expected to write all their personal data on a **standard application form**. Unfortunately, no two application forms are alike, and filling in each one may present unexpected difficulties. Some **personnel departments** or **human resources** believe that the CV and application letter give a better impression of a candidate than a form.

Therefore, when you **apply for a job**, you may need to fill in a **company application form** which asks for personal details, your qualifications, and your work history. Alternatively, you may be asked to supply a CV, which gives similar information, but which you write yourself. In either case, you will need to write a **covering letter** to go with the application form or CV. Most jobs are advertised in the papers or specialist publications, and before you write your covering letter you should study the wording of the advertisement carefully. Find out exactly what the employer is looking for (e.g., your working experience, knowledge of foreign languages, etc). Then in your covering letter, try to show that you have all the qualities, qualifications, and experience that the employer is looking for. Do not simply repeat all the information in the CV, but highlight the most important parts. There are different kinds of interviews: either traditional **one-to-one interviews**, or so called **panel interviews** where one or more candidates are interviewed by a panel interviewers. Sometimes applicants have to demonstrate how they can cope in actual business situations. The atmosphere of an interview may vary from the informal to

---

<sup>10</sup> CV abb. for curriculum vitae = a written record of your education and employment, that you send when you apply for a job; pronounced in AmE [ke,rikjelem 'vaiti:] and in BrE [ke,rikjelem 'vi:tai]; Americans use resume /'rezjumei/ more often

the formal and interviewers may take a friendly, neutral or even hostile approach. Different interviewers use different techniques and the only rules that applicants should be aware of may be "*Expect the unexpected*" and "*Be yourself*". Of course, **the salary** is an important part in the process of job hunting. Certain companies, beside a good salary may offer some extra benefits, such as a **company car** or **cheap housing loans**, bonuses paid in, the so-called "**thirteenth month**", **company pension schemes**, **free canteen meals**, **long holidays** or **flexible working hours**. All these definitely contribute to the attractiveness of a job. Ever since Croatia started democratic processes in the early nineties of the last century, some foreign companies and employers have been advertising posts in English emphasizing the need of applicant's fluent knowledge of at least one foreign language. Therefore, CVs and covering letters should be written in a foreign language, mostly English. The interviewers usually ask applicants to speak English and if they get the job, they are often sent to specialize abroad, usually to the country from which the employer comes from. For our graduates, knowing at least one foreign language is an imperative not only when European Union is regarded, but the Bologna process requirements are the same.

Now before looking at the following application forms, covering letters, CVs, imagine that you want to apply for the job and draft an application letter, following these guidelines:

- introduce yourself - name, age, nationality, etc
- state when you are available to start working
- describe your relevant experience - or justify your lack of experience.
- describe your skills in the languages required
- describe how you meet requirements for the job

### APPLICATION

Dear Sirs,

I would like to apply for the post of Development Engineer, as advertised in the April issue of Electronics Today. I enclose my CV with the name of one referee.

I consider myself well qualified for this post. My college work was good and I have completed all my modules successfully. I have just graduated from the Department of Electrical Engineering, the University of Applied Sciences in Kyiv. During the 6th term I completed student's practice in an electronics company. This provided valuable experience in the design, development, and production of electronic equipment and accessories. I would like to continue my education for another two years to get my Master's degree.

I am now looking for a permanent position in a dynamic, interesting and challenging working place which would give me an opportunity to fully realize my interests and qualities and to continue my education.

I am confident that with my relevant qualifications, knowledge of English and German, as well as my personal qualities, I will be able to satisfy all your requirements.

Please find attached a copy of my CV and reference.

Hoping that you would take my application under serious consideration, I remain,

Yours faithfully,

*HrVoje HprVatic*

Hrvoje Horvatic Enc: CV

### CHOOSE THE MOST APPROPRIATE WORD FROM THE OPTIONS IN BRACKETS

1. I am writing to (apply, request, ask) for the post of Sales Consultant advertised in today's

- edition of "The Guardian".
2. I enclose my curriculum vitae for the (job, position, work) of Program Manager.
  3. As you will see from the enclosed (CV, covering letter, application), I have had several years' experience of Export Sales.
  4. I (qualified, left, graduated) from Manchester Technical College with an HND in Electronic Engineering.
  5. At present, I am (worked, employed, taken) by Unisys, where I work in the Customer Services Department.
  6. I would be grateful if you could send me an application (form, formula, card).
  7. While I was at Dell, I was (liable, responsible, charged) for the day-to-day running of the Technical Services Department.
  8. At Data International my duties (included, added, completed) installing and testing new computer systems.
  9. I look (forward, ahead, on) to hearing from you.

**TICK THE ITEMS YOU THINK YOU SHOULD MENTION WHEN YOU APPLY FOR A JOB ADVERTISED IN THE NEWSPAPERS.**

- begin with the reference to where you saw the job advertised
- give details of the subjects you studied at school
- list briefly all previous jobs
- be honest and admit that you lack exactly the required experience
- indicate your current level of responsibility
- explain why the company would benefit if they employed you
- say when you will be available for interview
- request that they reply as soon as is reasonably possible

**MORE POSSIBLE QUESTIONS DURING THE JOB INTERVIEW:**

If you have done the exercise in Part 4, Job interview questions, here are some possible, unexpected and tricky questions which some of our students were asked:

1. Are you ready to work overtime?
2. What communication did you have with your ex-boss?
3. Do you mind working in a noisy environment?
4. How do you feel working with people whose national culture/race is different from yours?
5. Are you afraid of flying?
6. Are you willing to go on business trips?
7. Here is a scheme which is used in one of our production lines. Could you explain it to us?
8. What do you know about our company?
9. What salary do you expect?
10. Are you in a steady relationship?
11. Do you plan to marry in the near future?

**2 HOW TO WRITE A SUMMARY**

A summary or an abstract is a short piece of writing containing the main ideas in a document, research paper or professional article. In the majority of cases they are written in English. Therefore, it is advisable for prospective authors to know the principles and techniques used when summarizing a paper or an article. It contains only relevant, clear, and precise data concerning the paper; it comprises only the essential, basic information of the article in question.

Summarizing means condensing or shortening a reading selection while preserving its overall meaning in order to demonstrate your understanding of a reading, to establish ideas you need to discuss or analyze in an essay, or just to inform a group of listeners about the text or article.

A summary requires certain organization, i.e. it consists of the title, the introduction, the body and the conclusion. It keeps the same logical sequence as the article itself. The title must be as short as possible and is usually written in block letters. The introduction, the body and the conclusion should not exceed 100 words. Very rarely, more than 100 words are allowed. The style is neutral and impersonal, not "I", but "it", "they" sometimes "we". Almost all the tenses used for writing summaries are in the passive voice, the simple present tense being the most common. If chronological sequence is required, the simple past, present perfect and present simple are used. Short sentences are strongly recommended, they offer a quicker and better overview of the information.

The lexis used in technical writing is usually a mixture of general lexis, specific lexis used in all fundamental engineering branches and lexis used in specialized fields of science and engineering. Although it might seem difficult and demanding to write a summary, the first step is almost a "copy- paste" activity - all summaries usually begin with one of the following introductory phrases:

- This paper deals with
- This paper discusses
- This article gives a short description of
- This article shows the relationship between
- This paper explains the methods used to

Instead of "paper" or "article" you may say "the author". Then summarize the author's opinion on the subject discussed, highlight main ideas, rewrite the thought in your own words taking into consideration key words, be brief and accurate. Writing a summary is like writing hints or a crib sheet before an examination, however you have to make sentences out of them which would have the correct sentence scheme, i.e. Subject, Verb/Predicate and Object. Here is the summary for the paper "Description of Essential Factors for Successful Reform of Electricity Sector in Croatia" WSEAS Transactions on Power Systems, January 2006 (authors are from the Faculty of Electrical Engineering and Computing, Department of Power Systems):

*This paper deals with the problems concerning the choice of electricity market model in Croatia. At the moment, Ukrainian electricity market is opened app. 14%.*

*This is obviously too little particularly because the Republic of Croatia has started accession talks with the European Union regarding its membership and this membership implies faster opening of the market as well as the most efficient market model. It also gives positive and negative aspects of the regulation because regulation affects liberalization of electricity market very directly, encourages investments in power supply field and prevents monopolistic behaviour on the market. The presented scheme includes possible partners in the open power supply field as well as regulatory effect toward the market in the last three years. The*

*paper also analyzes the questions concerning the structure and organization of electricity market which are vital for the proper choice of electricity market model.*

*Key words - electricity market, license, market model, regulation of energy activities*

More about writing a summary, you will hear in the sixth semester, during the lecture.

And finally, if you think that writing a summary in English is difficult, it isn't easy for the English either. Just read the following notes made by Richard Lederer, an Englishman, in his essay called "English is a crazy language".

### **3 HOW TO WRITE A POWER POINT PRESENTATION**

#### YOU'RE GIVING A PRESENTATION...

Do this quiz about body language first. Sometimes more than one answer is possible:

1. How should you stand?
  - a) Arms crossed on chest.
  - b) Straight but relaxed.
  - c) Knees unlocked.
2. What should you do with your hands?
  - a) Put hands on hips.
  - b) Put one hand in a pocket.
  - c) Keep hands by your side.
3. How can you emphasize something?
  - a) Point finger at the audience.
  - b) Move or lean forward to show that something is important.
  - c) Use a pointer to draw attention to important facts.
4. What should you do when you feel nervous?
  - a) Hold pen or cards in your hands.
  - b) Walk back and forth.
  - c) Look at the flip chart or screen (not at the audience).
5. How should you keep eye contact with the audience?
  - a) Make eye contact with each individual often.
  - b) Choose some individuals and look at them as often as possible.
  - c) Spread attention around the audience.
6. How fast should you speak?
  - a) About 20% more slowly than normal.
  - b) Just as fast as in a normal conversation.
  - c) Faster than in a normal conversation.
7. How should you express enthusiasm?
  - a) By raising voice level.
  - b) By waving arms.
  - c) By making hand or arm gestures for important points.

(Suggested answers: 1) b 2) c 3) b/c 4) a 5) a/c 6) a 7) a/c)

#### **MAIN PARTS OF A PRESENTATION**

##### INTRODUCTION

Welcome audience:

- Good morning/afternoon, ladies and gentlemen.
- Hello/Hi, everyone.
- First of all, let me thank you all for coming here today.
- I'm happy/delighted that so many of you could make it today.

Introduce yourself (name, position/function):

- Let me introduce myself. I'm ..., a second-year student from the Department of Electrical Engineering, University of Applied Sciences in Kyiv.
- For those of you who don't know me, my name's ....., a second-year student from the Department of Electrical Engineering, University of Applied Sciences in Kyiv.
- As you probably know, I'm ....., a second-year student of the Department of Electrical Engineering, University of Applied Sciences in Kyiv

##### TODAY'S TOPIC IS ...

State your topic:

- since you are all students of Electrical Engineering, I'm sure you are familiar with the topic of my presentation. Anyway I'll give you a short Summary. Take your time to read it and then I'll continue
- As you can see on the screen, our topic today is ...
- Today's topic is ...
- What I'd like to present to you today is ...
- The subject of my presentation today is ...

Say why your topic is important for the audience:

- My talk is particularly relevant to those of you /us who ....
- Today's topic is of particular interest to those of you/us who ....
- The/My topic is very important for you because
- By the end of this talk you will be familiar with ....

Say how long the talk will be:

- My talk should take about 10 minutes. Please feel free to interrupt me at any time with questions.
- There will be time for questions after my presentation.

### MY FIRST SLIDE SHOWS ...

Say something about the Contents:

- I'll begin by showing you the main points of my presentation, these are..
- I'd like to give you an overview of my presentation; first of all, I'll be talking about..
- I'll show you how I have divided my presentation. The main points are..

Continue with showing them your slides

- my first slide shows.
- take a look at my first slide.
- as you can see here
- let me just show you ...
- to illustrate this ...
- my next slide shows ...
- to illustrate this, let's have a closer look at ...
- I have a slide here that shows ...
- I'd like to stress/highlight/emphasize the following point(s)..
- let me point out that ...
- I think you'll be surprised to see that ...
- what I'd like to point out here is ...
- I'd like to focus your attention

to. or/and graphs

- I'll show you two bar charts which illustrate/show...
- the left bar chart explains.
- when test results are introduced in the table, the basic flowchart below will illustrate ...



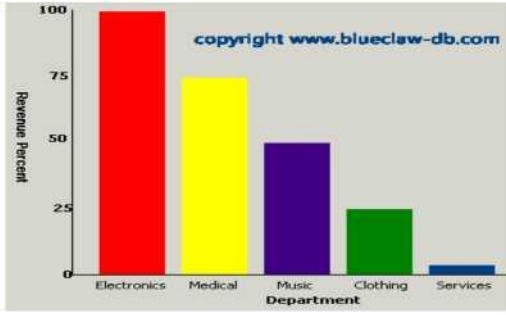
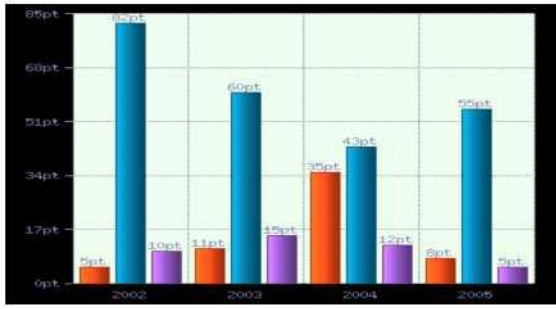

Basic Flowchart

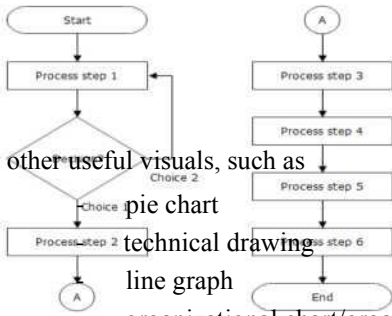

or other useful visuals, such as  
 pie chart  
 technical drawing  
 line graph  
 organizational chart/organogram

	A	B	C	D
1	ABCD		ABCD	ABCD
2	ABCD		ABCD	
3	ABCD	ABCD	ABCD	ABCD
4				
5			ABCD	
6				ABCD

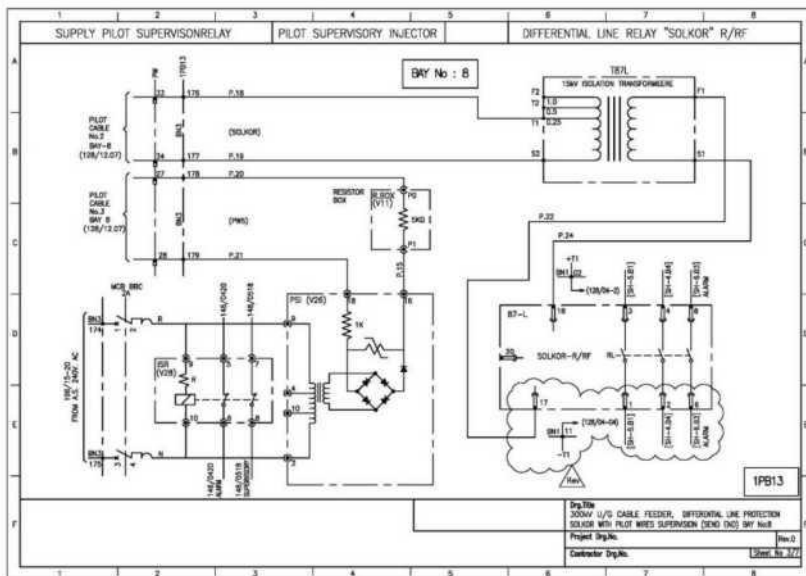
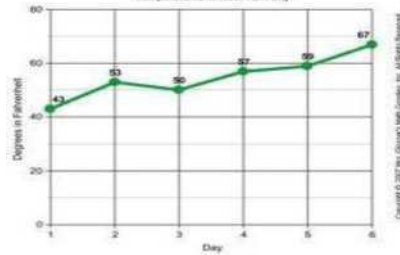

## TO SUM UP...

Signal the end of your presentation:

- I'm now approaching the end of my presentation
- Well, this brings me to the end of my presentation
- OK, that's everything I wanted to say about ...
- As a final point, I'd like to ...
- Before I stop, let me go over the key issues again ...
- Just to summarize the main points of my talk ...
- To sum up/To conclude/In conclusion, I'd like to

Invite questions:

- Are there any questions?
- We just have time for a few questions.
- And now I'll be happy to answer any questions you may have.
- Dealing with questions/clarifying questions:
- I'm afraid I didn't (quite) catch that.
- I'm sorry; could you repeat your question, please?
- So, if I understood you correctly, you would like to know whether ...

Avoiding giving an answer:

- If you don't mind, could we discuss that on another occasion?
- I'm afraid that's not really what we're discussing today.
- Well, actually I'd prefer not to discuss that today.

Admitting you don't know:

- Sorry, that's not my field.
- I'm afraid I'm not in the position to answer that question at the moment.
- I'm afraid I don't know the answer to your question, but I'll try to find out for you.

Asking questions:

- Well, if you don't have any questions, I'd like to ask some.
- Allow me to put some questions and give answers if needed
- I'd like to discuss some points, if you don't mind

Thank the audience

On his web site, the American presentations guru Charlie F. Elroy, talks about his strategies for good conclusion and says: "Forget standard phrases such as "Thank you very much for your attention" or "Thank you for listening". After a good presentation, it is the audience who should be thanking you!" Since we are not Americans, thank your audience, they will appreciate it, particularly if your presentation was not so good!

## **4 HOW TO WRITE A BUSINESS LETTER**

A business letter is more formal than a personal letter. It should have a margin of at least one inch on all four edges. There are 9 parts to a business letter.

- Heading or letterhead - includes your company's name, address, tel. number, fax number and email address. If possible include your web address. Then skip a line and write a date. Never abbreviate to Jan. 31. Write January 31.
- The inside address (recipient address) - make it as complete as possible, include titles and names of persons if known.
- Reference - it is optional. Obligatory when dealing with large volume of

correspondence. Start with Re:

- Salutation - also called greeting. Always formal. It begins with "Dear" and includes the person's last name. Always personalize the letter if the recipient is known. Otherwise - "Dear sir/madam:"
- Subject matter - optional, if there is reference, there is no subject and vice versa. Placed one line below the salutation.
- The body - written as text with paragraphs. Skip the line between paragraphs.
- Each paragraph deals with one point and one point only.
- The Complimentary close - always end with "Sincerely yours "- it can be preceded with longer line like "Looking forward to hearing from you" etc.
- Signature - Skip several lines (for the handwritten signature) after the close and type your name and your title. Women also indicate how they wish to be addressed - Miss, Mrs, Ms.
- Enclosures - if you include other material in the letter, put Enc or Encl, two lines below. Business letters should not contain postscripts.

#### **E-MAILS AND LETTERS - CHECK LIST**

- Always use a standard - There are differences between British English and American English customs in letter writing. British English is the standard in EU so stick to it.
- Always use a salutation (greeting) in English - In 99% of cases this will be with "Dear..." followed by the last name. The exceptions are letters of recommendation that start with "To whom it may concern".
- Always place the heading under the salutation
- Always try to round off a letter with "-ing forms" - These stress that you have an on-going relationship and there is unfinished business. Example: *We are looking forward to receiving your., We are looking forward to discussing. .etc.*
- •Always write the month in letters - Write the month in letters, e.g. 12 June 2005, or ISO standard for all-digit dates (CCYY-MM-DD) so 2005-06-12.
- •Never use a place-name in front of the date - Never write "Kyiv, 12 June 2005" Just write the date.
- •Never use exclamation marks (!) in business letters - An exclamation mark in English is used to express astonishment or surprise. You are very unlikely to need them in normal business letters, faxes or e-mails.
- •Never use short forms like "I'm" or "don't" in business letters - Use these only in informal, conversational writing and when reporting speech. Sometimes they are used in e-mails.
- •Never capitalize "you" and "your" in mid-sentence - Capitalized "You" and "Your" in mid sentence disappeared a few hundred years ago in the English language
-

### PART 3

### GLOSSARY

#### A

**acid rain** - rain that has become acidic due to the emission of sulphur dioxide and nitrogen oxides **active power** - see "real power"

**alternating current (AC)**- electric current that reverses direction periodically, usually many times per second

**alternator** - an electric generator designed to produce alternating current; it usually consists of rotating parts which created the changing magnetic field to produce the alternating current

**ambient temperature**- the surrounding temperature of an area

**ammeter** - an instrument used for measuring the electrical current flow in a portion of a circuit

**ampacity** - the current, in amperes, that a conductor can carry continuously under the conditions of use without exceeding its temperature rating.

**ampere** - a type of electric current produced by one volt applied across a resistance of one ohm, it is also equal to the flow of one coulomb per second; named after French physicist Andre M. Ampère in 1836

**amplification** - the process of increasing the strength (current, voltage, or power) of a signal

**analog** - a measuring or display methodology which uses continuously varying physical parameters while digital represents information in discrete binary form using only zeros and ones.

**analog(ue) signal** - the signal is varied continuously with respect to the information; the information in the signal is degraded by the noise

**appliance** - utilization equipment, generally other than industrial, normally built in standardized sizes or types, that is installed or connected as a unit to perform one or more functions such as clothes washing, air conditioning, food mixing, deep frying, etc.

**atomic number** - the number of elementary positive charges in the nucleus of an atom, it is a different number for each element, starting with 1 for hydrogen and going up beyond 103

**atomic orbital** - the region in space around the nucleus of an atom in which an electron with a given set of quantum numbers is most likely to be found

**B band** - a collection of orbitals, each delocalized throughout the solid, that are so closely spaced in energy as to be nearly continuous

**band gap** - the energy separation between the top of the valence band and the bottom of the conduction band

**battery** - a group of two or more cells connected together to provide electrical current. Sometimes also used to describe a single cell which converts chemical energy to electrical current.

**bias** - voltage applied to the electrodes in an electrical device, considering polarity

**biasing** - applying a voltage, often done to alter the electrical and optical output of a device such as a light emitting diode (LED)

**branch circuit** - the circuit conductors between the final overcurrent device protecting the circuit and the outlet(s)

**branch circuit, appliance** - a branch circuit that supplies energy to one or more outlets to which appliances are to be connected, and that has no permanently connected lighting fixtures that are not a part of an appliance.

**broadcast communication** - radio communication between one powerful transmitter and numerous receivers

## C

**capacitor** - a device that stores electrical charge usually by means of conducting plates or foil separated by a thin insulating layer of dielectric material. The effectiveness of the device, or its capacitance, is measured in Farads.

**cathode ray tube** - an electron-beam tube in which the electrons emitted by a hot cathode are formed by an electron gun into a narrow beam that can be focused to a small cross section of a fluorescent screen. The beam can be varied in position and intensity by internal electrostatic deflection plates or external electromagnetic deflection coils to produce a visible trace, pattern, or picture on the screen.

**cell** - a single device which converts chemical energy into electrical current. Sometimes also referred to as a battery.

**channel** - a division in a transmission medium resulting in the possibility of sending multiple streams of information

**charge coupled devices** - a charge transfer device that stores charge in potential wells and transfers it almost completely as a packet by translating the position of the potential well

**choke coil** - an inductance device used in a circuit to present a high impedance to high frequencies without appreciably limiting the flow of direct current

**circuit** - arrangement of one or more complete paths for electron flow; a closed loop of conductors through which charges can flow

**circuit breaker** - a device designed to open and close a circuit by non-automatic means and to open the circuit automatically on a pre-determined overcurrent without damage to itself when properly applied within its rating

**cleaved-coupled-cavity (Cf31)** - two or more aligned semiconductor lasers which through destructive and constructive interference are able to output light of a particular wavelength

**conduction band** - the unfilled energy levels into which electrons can be excited to become conductive electrons; a band that when occupied by mobile electrons, permits their net movement in a particular direction, producing the flow of electricity through the solid

**conductor** - a material which permits the flow of free electrons; a material with a high electrical conductivity such as copper or aluminium

**continuous load** - a load where the maximum current is expected to continue for 3 hours or more.

**controller** - a device or group of devices that serves to govern, in some predetermined manner, the electric power delivered to the apparatus to which it is connected

**copper** - a metallic element that has excellent conductivity of heat and electricity, good ductility and malleability, it is easily alloyed

**crystal** - a solid composed of atoms, ions, or molecules arranged in an orderly pattern that is repeated in three dimensions

**current** - the flow of electricity commonly measured in amperes; the rate of transfer of electricity from one point to another; current is usually a movement of free electrons

## D

**delocalized** (electrons) - electrons that are no longer bound to a given atomic nucleus and are highly mobile

**device** - a unit of an electrical system that is intended to carry but not utilize electric energy.

**digital signal** - the information is encoded as a set of discrete values (ones and zeros); the information remains intact unless the noise exceeds a certain threshold

**diode** - an electronic semiconductor device that predominantly allows current to flow in only one direction; a two electrode semiconductor device that utilizes the rectifying properties of a p-n junction or a point contact

**direct current (DC)** - electric current which flows in one direction only; circuit in which the flow of electrons is in one direction only, from anode to cathode

**distribution equipment** - a device designed to provide electricity to multiple connections divided among the components according to their resistances and impedances

**dopant** or **doping agent** - an impurity element deliberately added to a semiconductor material under precisely controlled conditions to create PN junctions required for transistors and semiconductor diodes

**drift velocity** - the average velocity of a carrier that is moving under the influence of an electric field in a conductor, semiconductor, or electron tube

## E

**electric generator** - a device which takes mechanical energy as an input and produces electricity (AC/DC) as an output

**electric motor** - a machine that converts electric energy into mechanical energy by utilizing forces exerted by magnetic fields produced by current flow through conductors

**electrical conductivity** - the ability of a material to conduct an electric current, as measured by the current per unit of applied voltage; it is the reciprocal of resistivity

**electrical resistance** - the measure of the difficulty of the electric current to pass through a given material; its unit is the ohm ( $\Omega$ )

**electricity** - current passing through a conductor from a region of high potential to low potential

**electrolysis** - the production of chemical changes by passing current from an electrode to an electrolyte, or vice versa

**electromagnetic induction** - the production of a voltage in a coil by a change in the number of magnetic lines of force passing through the coil

**electromagnetic radiation** (waves) - a series of energy waves that travel in a vacuum at the speed of  $3 \times 10^8$  m/s; includes radio waves, microwaves, visible light, infrared, and ultraviolet light, x-rays, and gamma rays

**electromotive force** - the force that tends to produce an electric current in a circuit, usually called voltage

**electron** - a negatively charged sub-atomic particle whose mass is  $9.1 \times 10^{-31}$  kg **electron energy level** - In quantum mechanics, an energy which is allowed for an electron

**electron flow** - a current produced by the movement of free electrons toward a positive terminal; the direction of electron flow is opposite to that current

**electron gun** - an electron structure that produces and may control, focus, deflect, and converge one or more electron beams in an electron tube

**electronics** - the branch of science or technology that deals with electron devices, including electron tubes, magnetic amplifiers, transistors, and other devices that do the work of electron

tubes in controlling the flow of electricity in a vacuum, gas, liquid, semiconductor, conductor or superconductor

**enclosure** - the case or housing of an apparatus, fence, or walls that prevent persons from accidentally contacting energizing parts, or to protect the equipment from physical damage

**energizing** - electrically connected to a source of potential difference

**energy** - the capacity for, or the ability to do, mechanical work. Electrical energy is measured in kilowatt-hours for billing purposes.

**energy saving devices** - devices utilized within a dwelling designed to more efficiently make use of energy sources while providing heating, cooling, and light

**equipment** - a general term including materials, fittings, devices, appliances, fixtures, apparatus, and the like used as a part of, or in connection with, an electrical installation

**extrinsic semiconductor** - a semiconductor material that has been doped with an n-type or p-type element

## F

**fault** - a short circuit in an electrical system.

**fluorescent lamps** - fluorescent lamps produce light by passing electricity through a gas, causing it to glow. The gas produces ultraviolet light; a phosphor coating on the inside of the lamp absorbs the ultraviolet light and produces visible light. Fluorescent lamps produce much less heat than incandescent lamps and are more energy efficient. Linear fluorescent lamps are used in long narrow fixtures designed for such lamps. Compact fluorescent light bulbs have been designed to replace incandescent light bulbs in table lamps, floodlights, and other fixtures.

**fly-back** - also called *retrace* - the return of the electron beam to its starting point in a cathode-ray tube after a sweep

**forward bias** - bias applied to a p-n junction in the conducting direction, majority carrier electrons and holes flow toward the junction so that a large current flows

**free electron** - an electron that is not constrained to remain in a particular atom, it is therefore able to move freely in matter or a vacuum, when acted on by external electric or magnetic field

**frequency** - in alternating current, the rate at which the current changes direction. One complete cycle is a unit of 1 Hertz, named after the physicist who researched AC

## G

**galvanometer** - an instrument for measuring a small electric current

**generator** - an electric machine for generating electromotive force (voltage); a rotating machine which converts mechanical energy into electrical energy

**germanium** - element 22, used mostly in early semiconductor devices

**grid** - an electrode located between the cathode and anode of an electron tube and having one or more openings through which electrons or ions can pass under certain conditions. A grid controls the flow of electrons from cathode to anode.

**grid** - in an electrical system, a term used to refer to the electrical utility distribution network

**ground (wire)** - a conducting connection, whether intentional or accidental, between an

electrical circuit or equipment and the earth, or to some conducting body that serves in place of the earth

**grounded** - connected to earth or to some conducting body that serves in place of the earth

## H

**heater** - a heat source (gas or electric) used to adjust the temperature inside a dwelling from a cold to a warm condition

**hertz (Hz)** - the unit of frequency (not just electricity, but also, for example, sound waves)

**high-tech troubleshooting** - a procedure performed by a trained technician for the purpose of locating and identifying electrical problems within an electrical system.

**hole** - a fictitious mobile particle that behaves as though it is a positively charged particle; holes are produced in the valence band when electrons from the valence band are promoted to the conduction band or an acceptor level of a p-type dopant

**horsepower** - a unit of power equal to 746 watts

## I

**impedance** - the total effects of a circuit that oppose the flow of an AC current consisting of inductance, capacitance, and resistance. It can be quantified in the units of ohms.

**impulse** - a current surge

**incandescence** - emission of visible radiation by a heated object, such as a lamp filament heated by electric current

**incandescent light** - a gas filled (argon) bulb containing a metallic filament (tungsten) that produces light when a sufficient voltage is applied; an ordinary light bulb

**incandescent light bulb** - incandescent light bulb produces light by passing electricity through a thin filament, which becomes hot and glows brightly. Incandescent light bulbs are less energy-efficient than fluorescent lamps, because much of the electrical energy is converted to heat instead of light. The heat produced by these bulbs not only wastes energy, but can also make a building's air conditioning system work harder and consume more energy.

**insulation** - a material having a high resistance to the flow of electric current; insulation over underground conductor is made of either EPR or XLPE material

**insulator** - a material with a low electrical conductivity; a type of material having a lower energy valence band that is nearly completely filled with electrons and a higher conduction band that is nearly completely empty of electrons as a result of a large energy gap between the two bands

**integrated circuit (IC)** - a single semiconductor chip or wafer which contains thousands or millions of circuit elements per square centimetre

**integrated circuit (IC)** - a single semiconductor chip or wafer which now contains thousands or millions of circuit elements per square centimeter

**interrupter** - an element designed to interrupt specific currents under specified conditions. **intrinsic semiconductors** - a semiconductor material that is essentially pure

**inverter** - an electrical device which is designed to convert direct current into alternating



current. This was originally done with rotating machines which produced true sine wave ac output. More recently this conversion has been performed more economically and efficiently using solid state electronics. However, except for the most expensive models, these devices usually do not produce perfect sine wave output. This sometimes can result in electromagnetic interference with other sensitive electronic devices.

**ion** - an ion is a positively or negatively charged atom or molecule

**ionization** - a process by which a neutral atom or molecule loses or gains electrons, thereby acquiring a net charge and becoming an ion; it can be produced by collision of particles, i.e. by collisions between electrons and residual gas molecules in an electron tube (=ionization current or gas current), by radiation, and by other means

## J

**Joule**- a unit of work or energy equal to one watt for one second. One kilowatt hour equals 3,600,000 Joules. Named after James P. Joule, an English physicist 1889.

**Joule's Law**- defines the relationship between current in a wire and the thermal energy produced. In 1841 an English physicist James P. Joule experimentally showed that  $W = I^2 \times R \times t$  where I is the current in the wire in amperes, R is the resistance of the wire in Ohms, t is the length of time that the current flows in seconds, and W is the energy produced in Joules.

## K

**kilovolt** - a unit of electrical potential equal to 1,000 volts; abbreviated kV or KV. **kilowatt (kW)** - real power delivered to a load (W x 1,000 VA)

**kilowatt-hour** - a unit of energy or work equal to one kilowatt for one hour; abbreviated as kwh or KWH. This is the normal quantity used for metering and billing electricity customers.

## L

**lagging load** - inductive type load

**laser diode** - a solid-state semiconductor device that is capable of emitting coherent light **leading load** - capacitive load

**leads** - wire segments used to connect devices in electric circuits

**light emitting diode (LED)** - a semiconductor p-n junction device that is optimized to release light of approximately the band gap energy when electrons fall from the conduction band to the valence band

**like charges** (+ & + and - & -) - repel each other

**limit switch** - a switch that is operated by some part or motion of a power-driven machine or equipment to alter the electric circuit associated with the machine or equipment

**liquid-filled transformer** - a transformer in which the core and coil are immersed in a liquid which acts as both a cooling and insulating medium.

**live part** - electric conductors, buses, terminals, or components that are uninsulated or exposed and an electric shock hazard exists

**load** - the load of a transformer is the power, in kVA or volt-amperes, supplied by the transformer **load centre** - source for all power to the home. All circuits originate from the

"Load Centre" or "Service Panel." Circuit breakers are located within this panel.

**load curve** - a curve showing instantaneous demand (kVA or MVA) versus time. Curves are usually plotted for one day or one week. Integrating the load curve will provide the amount of energy consumed.

**load break** - the ability of a switching device to disconnect a load current without damage

**load factor** - represents how efficiently the electrical system capacity is being used. The higher the load factor the higher the efficiency.

**load switching** - transferring the load from one source to another

**low voltage** - a wiring system that provides power to some electronic devices operating on a voltage level much lower than the standard one

## M

**metal** - a material with a partially filled energy band; metals are generally malleable, ductile, good reflectors of electromagnetic radiation, and good conductors of heat and electricity; metals are usually identified by having electrical conductivities that decrease with increasing temperature

**metal enclosed** - surrounded by a metal case of housing, usually grounded

**metal clad** - devices in which the conducting parts are entirely enclosed in a metal casing

**modulation** - the shaping of a signal to convey information

**monolithic IC technology** - a technique of circuit fabrication where all of the devices in a circuit are placed on the same chip

**motor** - an electronic device used to move, switch, or adjust one or more of the systems within a dwelling

**multimeter** - a volt-ohm-milliammeter combined into one device

## N

**network** - transmitters, receivers or transceivers communicating with each other

**neutral grounding resistor** - a grounding device, the principal element of which is resistance, which is used to connect the neutral point of the transformer to earth

**non-renewable energy sources** - fossil fuels such as oil, natural gas and coal and nuclear fuel

**n-type semiconductor** - a semiconductor that has been doped with an electron donor

## O

**Ohm** - the unit of measure for resistance

**ohmmeter** - an instrument for measuring electric resistance

**opto-electronic** - materials that can either produce an electric current from light or produce light from a current

**orbital or planetary electron** - an electron that moves in orbit around the nucleus of an atom

**oscilloscope** - a test instrument that uses a cathode-ray tube to make visible on a fluorescent screen the instantaneous values and waveforms of electrical quantities which are rapidly varying as a function of time or another quantity

**outlet** - a point on the wiring system at which current is taken to supply utilization equipment

**overload** - operation of equipment in excess of normal, full-load rating, or of a conductor in excess of rated ampacity that, when it persists for a sufficient length of time, would cause damage or dangerous overheating. A fault, such as a short circuit or ground fault, is not an overload.

**overvoltage** - a voltage above the normal rated voltage or the maximum operating voltage of a device or circuit. A direct test overvoltage is a voltage above the peak of the line alternating voltage.

## **P**

**parallel circuit** - a circuit in which the same voltage is applied to all components, and the current is divided among the components according to their resistances and impedances

**photo-cathode** - a photosensitive surface that emits electrons when exposed to light or other suitable radiation; used in photo-tubes, television camera tubes, and other light-sensitive devices

**photocell** - a solid state photosensitive device whose current-voltage characteristic is a function of incident radiation; "electric eye" or "photoelectric cell"

**photoconductivity** - light shining on the surface of a material increasing the conductivity

**photon** - a massless particle, the quantum of the electromagnetic field carrying energy, also known as the light quantum

**photoresistor** - a device for measuring or detecting electromagnetic radiation. The conductivity of the resistor changes with exposure to light.

**p-n junction** - a boundary between p-type and n-type regions within a single crystal of a semiconductor material, a diode

**point-to-point communication** - communication between one transmitter and one receiver

**power electronics** - the [technology](#) associated with the efficient conversion, control and conditioning of electric power by static means from its available input form into the desired electrical output form

electrons, but may also be a movement of positive and negative ions, or holes

**power outlet** - an enclosed assembly that may include receptacles, circuit breakers, fuse holders, fused switches, buses, and watt-hour meter mounting means; intended to supply and control power to mobile homes, recreational vehicles, park trailers, or boats; or to serve as a means for distributing power required to operate mobile or temporarily installed equipment.

**primary voltage rating** - designates the input circuit voltage for which the primary winding is designed.

**primary winding** - symbol P, the transformer winding that receives signal energy or AC power from a source; also called primary

**Principle of the conversion of energy** - energy cannot be created or destroyed, but it may be converted from one form into the other

**p-type semiconductor** - a semiconductor that has been doped with an electron acceptor

**puncture** - the term used when a disruptive discharge occurs through a solid dielectric. A disruptive discharge in a solid dielectric produces a permanent loss of dielectric strength; in a liquid or gaseous dielectric, the loss may be only temporary.

## Q

**quantum mechanics** - physical laws governing the behavior of matter and energy on a very small scale

**quantum numbers** - a set of four numbers necessary to fully characterize the state of each electron in an atom

## R

**radar receiver** - a high-sensitivity radio receiver that amplifies and demodulates radar echo signals and feeds them to a radarscope or other indicator

**rainproof** - constructed, protected, or treated so as to prevent rain from interfering with the successful operation of the apparatus under specified test conditions

**reactive power** - the mathematical product of voltage and current consumed by reactive loads. Examples of reactive loads include capacitors and inductors. These types of loads when connected to an ac voltage source will draw current, but since the current is 90° out of phase with the applied voltage they actually consume no real power in the ideal sense.

**reactor** - a device for introducing inductive reactance into a circuit for motor starting, operating transformers in parallel, and controlling current.

**real power** - the rate at which work is performed or that energy is transferred. Electric power is commonly measured in watts or kilowatts. The term real power is often used in place of the term power alone to differentiate from reactive power. Also called active power.

**receptacles** - power sources located throughout a building to provide electricity where needed.

**rectifier** - a circuit component, usually a diode, that allows current to flow in one direction unimpeded but allows no current flow in the other direction

resistance - the opposition that a device or material offers to the flow of direct current

**resistor** - a device used in electric circuits to limit the current flow or to provide a voltage drop

**resistor** - any device of material that limits the flow of current when voltage is applied.

**reverse bias** - bias applied to a p-n junction in a direction for which the flow of current is inhibited; majority carrier electrons and holes flow away from the junction

## S

**scan** - to examine an area or a region in space point by point in an ordered sequence, as when converting a scene or image to an electric signal or when using radar or monitor an airspace for detection, navigation, or traffic control purposes

**secondary winding** - symbol S, a transformer winding that receives energy by electromagnetic induction from the primary winding. A transformer may have several secondary windings, and they may provide AC voltages that are higher, lower, or the same as that applied to the primary winding; also called secondary.

**semiconductor** - a material whose electrical conductivity is midway between that of a good conductor and a good insulator; a type of material having a lower energy valence band that is nearly completely filled with electrons and a higher energy conduction band that is nearly completely empty of electrons, with a modest energy gap between the two bands; pure materials usually exhibit electrical conductivity that increases with temperature because of an

increase in the number of charge carriers being promoted to the conduction band

**series circuit** - a circuit in which all parts are connected end to end to provide a single path for the current

**series gap** - internal gap(s) between spaced electrodes in series with the valve elements across which all or part of the impressed arrester terminal voltage appears

**series/multiple** - a winding of two similar coils that can be connected for series operation or multiple (parallel) operation

**service** - the conductors and equipment for delivering electric energy from the serving utility to the wiring system of the premises served

**service cable** - service conductors made up in the form of a

cable **silicon** - element 14, the most commonly used semiconductor

**smoke And carbon dioxide detector** - wall and ceiling mounted sensors located throughout the home used to alert occupants of deadly gasses and smoke inside the home

**subatomic** - pertaining to particles smaller than atoms, such as electrons, protons and neutrons

**sweep** - the steady movement of the electron beam across the screen of a cathode-ray tube, producing a steady bright line when no signal is present

**switch limit** - a switch that is operated by some part or motion of a power-driven machine or equipment to alter the electric circuit associated with the machine or equipment.

**switchboard** - a large single panel, frame, or assembly of panels on which are mounted, on the face or back, or both, switches, overcurrent and other protective devices, buses, and usually instruments. Switchboards are generally accessible from the rear as well as from the front and are not intended to be installed on cabinets.

**symmetric** - a term used to explain the normal, rhythmic ac flow of current; the steady state component of any current or fault current calculation.

**systems capacity** - represents the ability of a system to meet its customers' needs, or meet the electrical demand of its customers. System capacity is provided by generators, transmission lines, distribution networks and load management.

## T

**tap** - a connection brought out of the winding at some point between its extremities, usually to permit changing the voltage or current ratio

**television set** - a receiver that converts incoming television signals into the original scenes along with the associated sounds; also called *television receiver*

**thermistor** - a resistive circuit component having a high negative temperature coefficient of resistance so that its resistance decreases as temperature increases

**thermostat** - a low voltage electronic switching device that monitors temperatures inside the home and turns on and off the heating or cooling system in the home

**track and accent lighting** - condition specific lighting that meets special lighting requirements, providing variable lighting degrees of light and may distribute light in multiple directions

**transfer switch** - an electronic device that under certain conditions will disconnect from one power source and connect to another power source

**transformer** - a component that consists of two or more coils which are coupled together by magnetic induction; it is used to transfer electric energy from one or more circuits to one or more other circuits without change in frequency but usually with changed values of voltage and

current

**transformer** - a magnetic coupling device in an AC circuit; they are capable of changing voltages as needed

**transformer** - a static electrical device which by electromagnetic induction transfers electrical energy from one circuit to another circuit usually with changed values of voltage and current in the process

**transient** - a high amplitude, short duration pulse superimposed on the normal voltage.

**transistor (TRANSfer resISTOR)**- a solid state semiconductor device able to amplify a signal in forward bias; an active semiconductor device that has three or more electrodes, i.e. emitter, base and collector; it can perform practically all the functions of tubes, including amplification and rectification

**U**

**uninterruptible power supply** - a device that provides a constant regulated voltage output in spite of interruptions of the normal power supply. It includes filtering circuits and is usually used to feed computers or related equipment which would otherwise shutdown on brief power interruptions. Abbreviated UPS.

**unlike charges** (+ & -) - attract each other

**V**

**valence band** - the energy band containing the valence (outer) electrons; in a conductor the valence band is also the conduction band; the valence band in a metal is not full, so electrons can be energized to other levels and become conductive

**vapour barrier** - also called a vapour retarder, this is a material that retards the movement of water vapour through a building element (such as walls, floors, and ceilings) and prevents metals from corroding and insulation and structural wood from becoming damp

**ventilated** - provided with a means to permit circulation of air sufficient to remove an excess of heat, fumes, or vapours

**Volt** - the electrical potential difference or pressure across a one ohm resistance carrying a current of one ampere. Named after Italian physicist Count Alessandro Volta 1745-1827.

**Volt Ampere** - a unit of apparent power equal to the mathematical product of a circuit voltage and amperes. Here, apparent power is in contrast to real power. On ac systems the voltage and current will not be in phase if reactive power is being transmitted. Usually abbreviated VA.

**voltmeter** - an instrument used for measuring the potential difference between two points in volts

**W**

**waterproof** - constructed or protected so that exposure to the weather will not interfere with successful operation

**watertight** - constructed so that moisture will not enter the enclosure under specified test conditions

**Watt** - a unit of power equal to the rate of work represented by a current of one ampere under a pressure of one volt. Named after the Scottish engineer James Watt, 1819.

**waveform** - the shape of a wave, as obtained by plotting a characteristic of the wave with respect to time

**wiring** - a distribution network of wire that conducts electricity to receptacles, switches and appliances throughout a building/home to provide electricity where needed

**X plate** - one of the two deflection electrodes used to deflect the electron beam horizontally in an electrostatic cathode-ray tube

**Y**

**Y plate** - one of the two deflection electrodes used to deflect the electron beam vertically in a CR

## References

### Basic

1. Glendinning Eric H., McEwan John. Oxford English for Electronics Oxford University Press, 2000. — 208 p.
2. Glendinning Eric H., Glendinning Norman. Oxford English for Electrical and Mechanical Engineering Student book. — Oxford University Press, 1995. — 191 p. — ISBN: 0-19-457392-3

### Additional

1. Giancoli Douglas C. Physics. Principles with Application / Douglas C. Giancoli. —New Jersey: Prentice Hall, Upper Saddle River, 1998. —1096 p.
2. Graver B.D. Advanced English Practice / B.D. Graver. — Oxford University Press, 1996. — 320 p.
3. Shipman J.T. An Introduction to Physical Science / J.T. Shipman, J.D. Wilson. —Massachusetts Toronto: D.C. Heath and company, 1990. —630 p.