

UDC 621.941-229.3:621.822.172

DOI: 10.25140/2411-5363-2020-3(21)-135-141

*Peter Marcinko, Mikuláš Hajduk*

## **AUTOMOBILE POWERED BY COMPRESSED AIR, PNEUMATIC CAR 2020**

**Urgency of the research.** The issue of a pneumatic car – air car developing is very important nowadays, as the environment is threatened by a variety of emissions from cars. The decision has to be made. There are various alternatives to internal combustion engines, and one of them is compressed air engines.

**Target setting.** The main goal is to develop a car that runs on compressed air and create a frame that matches the dimensions specified for the competition.

**Actual scientific researches and issues analysis.** In recent years, Aventics has organized competitions and races on pneumatic vehicles. These races have been running by Emerson for thirteen years. The pneumatic cars had to take part in all categories of competitions. We have been dealing with this issue in Slovakia for the third year, and this pneumatic car is our third model.

**Uninvestigated parts of general matters defining.** This article describes a car that runs on compressed air, as well as describes in more detail the frame used and its design features.

**The research objective.** The purpose of this study is to analyze the pneumatic vehicle, its parts and to give a detailed description of the manufactured frame and its properties. The corresponding frame was made on the basis of the conditions determined by Emerson's competitions.

**The statement of basic materials.** The analysis was conducted on the basis of the terms of the competition. These conditions are determined by the maximum and minimum dimensions of the car. Based on these conditions, a frame was developed, it was previously analyzed by FEA - MKP. The description of the frame is given below.

**Conclusions.** This article describes the design of a pneumatic car for competitions. The competition focus is cars powered by compressed air. The pneumatic cars were developed by bachelors and technical school. The design of this car has passed the initial inspection and has been approved by the organizers of the competition.

**Keywords:** compressed air; pneumatic car; frame.

*Fig.: 7. References: 10.*

**Problem definition.** The basic concept is based on the rules of the XIII International Competition of Pneumatic Motorists Aventics. This is a competition of students' teams that include future bachelors and engineers. This year the third concept of the pneumatic car has been developed for this competition [1].

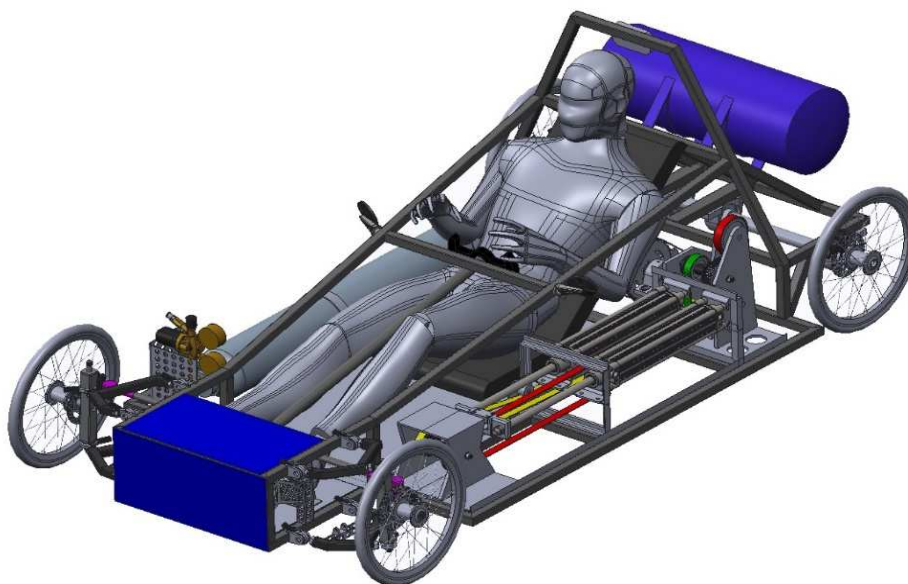

*Fig. 1. Designed vehicle – pneumatic car*

This model has four wheels as well as two cylinders used as a drive. This type of drive does not produce harmful emissions. The car offered (Fig. 1) can participate in competitions with a restored or new car. This year a new one has been built, the total weight of which does not exceed 90 kg.

The dimensions of this car met the requirements. The maximum length of the car is 2500 mm, and the maximum width is 1700 mm. The height is 90% of the width. The ground clearance between the bottom of the vehicle and the ground must be at least 70 mm. The proposed vehicle with the specified dimensions is shown in Fig. 2.

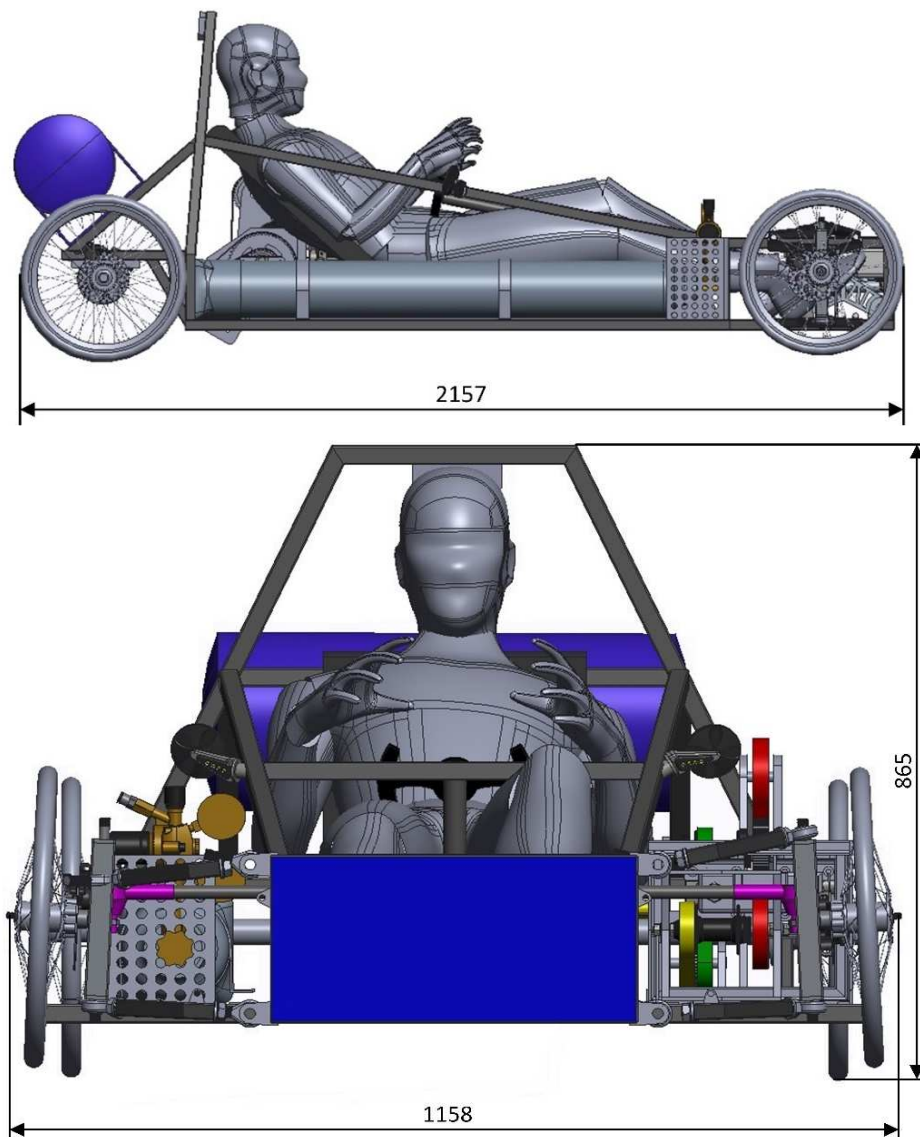

*Fig. 2. Pneumatic car with dimensions*

This year a concept consisting of a simple design has been proposed. The structure is strong, and a steel profile is chosen as a building material. Last year, three wheels could be used to design the concept. The rules of the competition no longer provide for the concept of three wheels, so the design was developed that now 4 wheels are used. The vehicle designed in this way is more stable in corners [2].

The frame was made of square and rectangular steel profile pipes, as they are easier to work with than round ones. The main structure consists of square pipes measuring 25x25x2 mm, as required by the rules, the load-bearing structures will be made of pipes of different sizes taking into account their purpose [3].

**Features of the frame.** The car is 2157 mm long, 1158 mm wide and 865 mm high. Approximately 90 kg is the maximum weight of the car. The height of the ground clearance is 90 mm. This new concept is a vehicle that can cover the maximum distance using less compressed

air. We chose a four-wheeled concept with a radius of 16 inches. It was decided to use the engine, which will consist of two air cylinders with a diameter of 63 mm and a piston stroke of 320 mm located on the left side of the car. The driver is located right in the middle of the car. A compressed air tank is installed on the right side of the car. The gearbox is located behind the driver's seat. The engine is controlled by the Arduino Mega 2560 system [4].

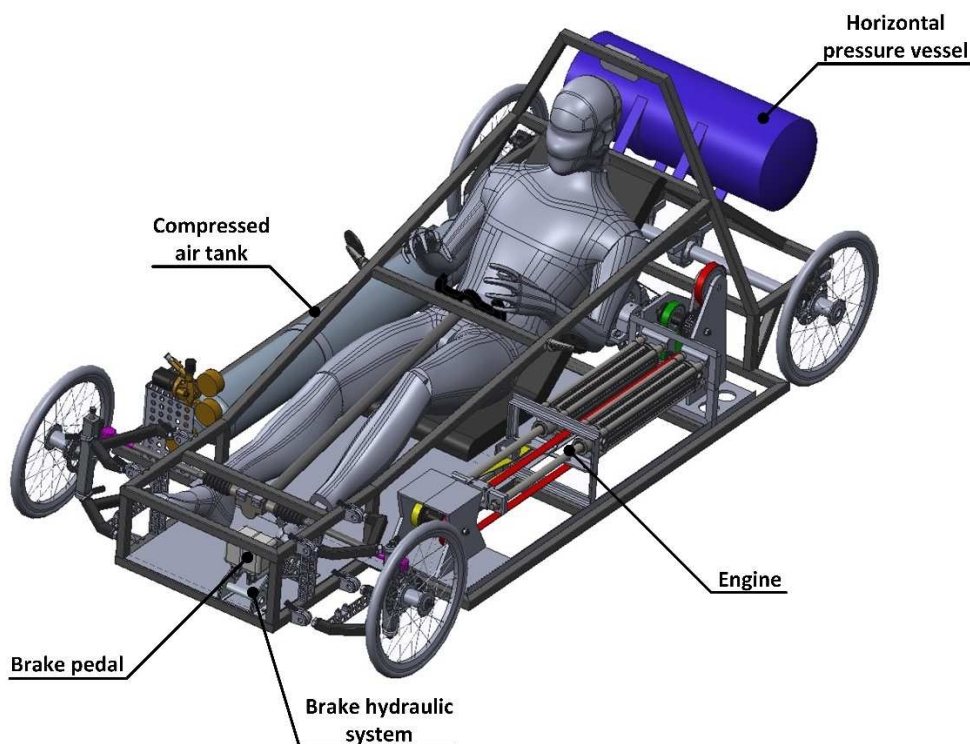

*Fig. 3. Pneumatic car and basic parts*

In order to meet the conditions of the competition, it was necessary to adhere to the stated dimensions. Since the decision on the concept of four wheels has been made this year, there have been several changes compared to the first concept. The frame can narrow with these changes and thus decreases overall. The driver's seat is located in the middle of the car. The frame of the vehicle serves as a protective frame. The frame created in this way protects the driver even in case of a collision or overturning. The concept was developed for maximum driver protection [5].



*Fig. 4. Comparison of the first and third concept*

**Collision simulations.** In the first study, a frontal collision was simulated by applying a force of 10 kN to the front of the frame. The frame showed minimal deformation, and the maximum stress reached only half the yield strength. Carried out simulation of a head-on collision and overturning of the car is shown in Figure 5 [6].

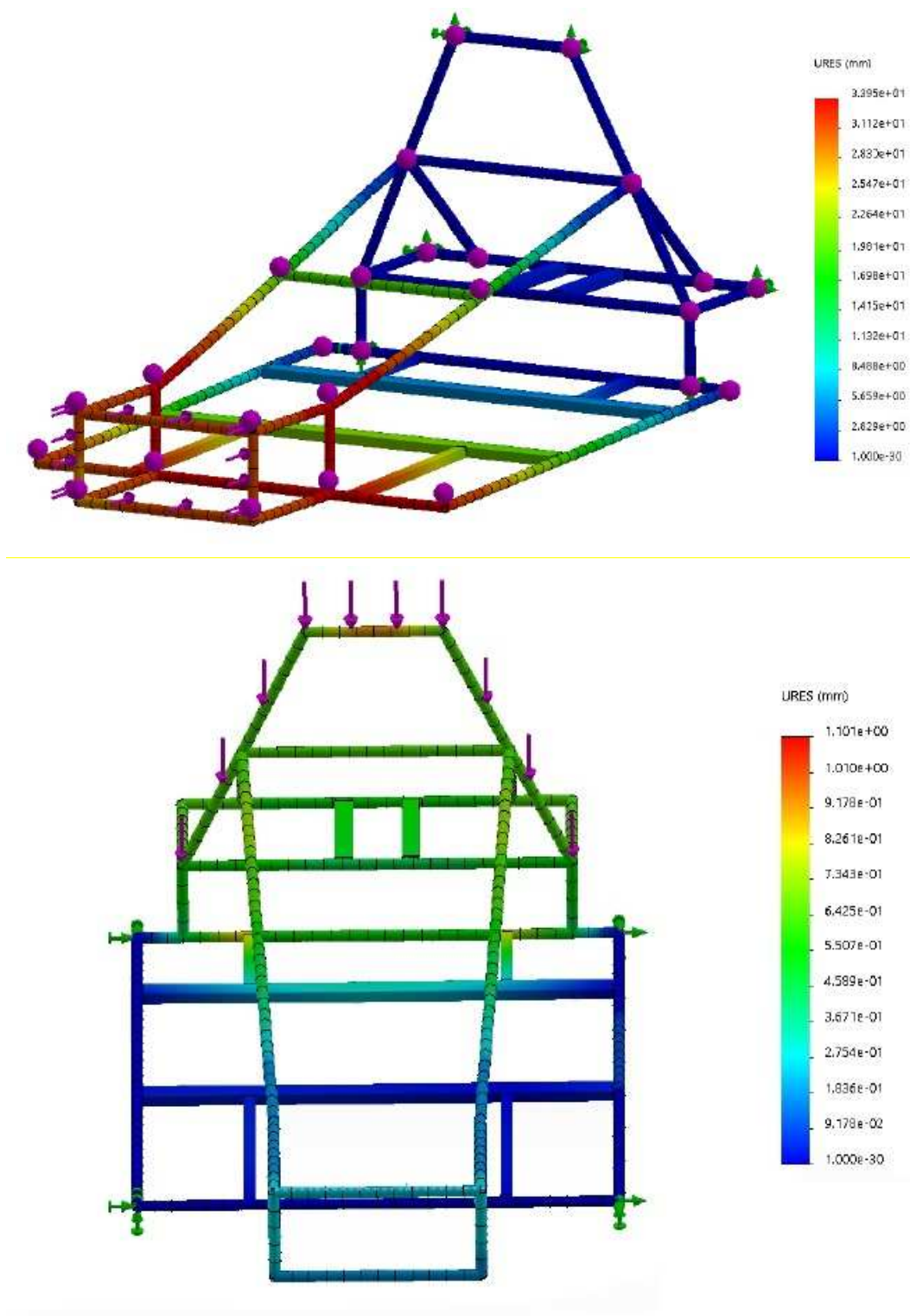

*Fig. 5. Simulation of the frame*

The front axle is sprung, the rear axle is stationary. The ground clearance of the front axle varies from 80 mm to 94 mm during the suspension, the rear axle has a fixed clearance of 94 mm [7]. **Control system of vehicle.** This vehicle uses two linear cylinders. The cylinders are connected by a belt. This engine is designed by Arduino - Mega. The whole system is powered by a lithium-polymer battery 6S - 1 P, 24 V with a capacity of 10,000 mAh [8].

The diagrams start by checking the emergency stop button (SBE). After that, if the emergency stop button is on, the system will stop and both cylinders will be empty, if the emergency stop button is off, the system will continue to operate. After applying the power to the Arduino-Mega controller, the driver must adjust the settings on the display. After that, the Arduino Mega controller reads the signal on all sensors. Then all values are shown on the display. The system continues to check the brakes. If the brakes are on, both cylinders (C1, C2) will go out and the brake lamp will light up. Otherwise the system continues to check the accelerator pedal, the brake light will go out. If the accelerator pedal is switched off, the air supplied to both cylinders will be switched off. If the pedal is on, the system continues to check the mode. If the signal from the ST6 sensor is correct and the signal from the ST6 sensor is incorrect, then the pistons are pushed out. If the signal from the ST6 sensor is incorrect, but the signal from the ST6 sensor is correct, then the pistons are retracted into the cylinder. Then the cycle repeats.

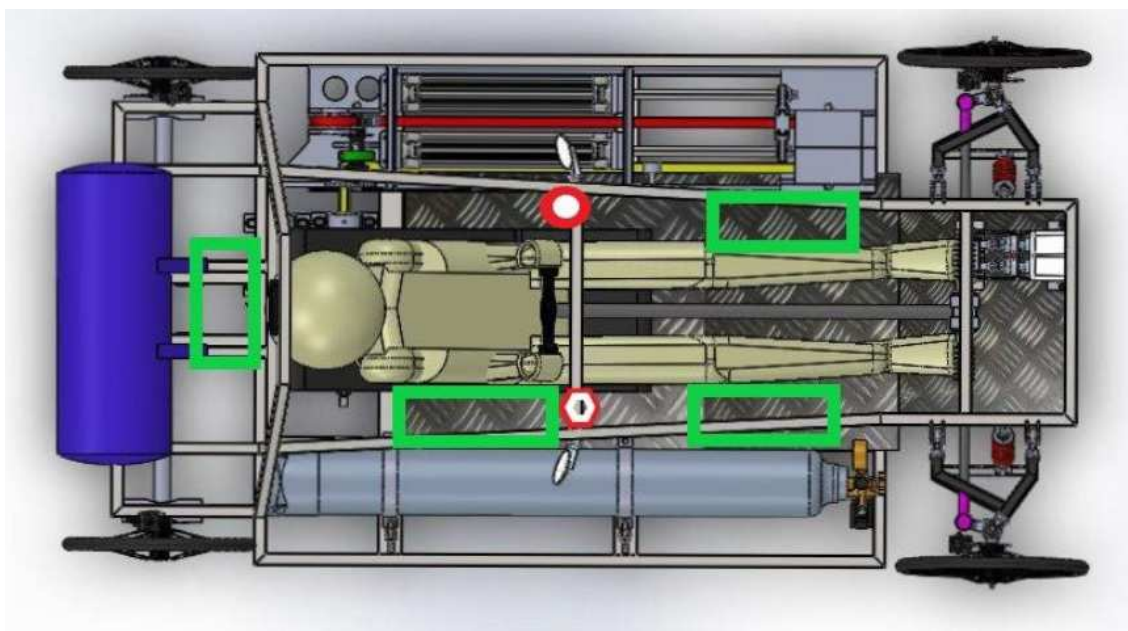

*Fig. 6. Planned position of electrical parts*

The electrical cabinet will be located in one of the positions marked by orange rectangles, the exact position will be selected when assembling the car with an emphasis on safety, weight distribution, cable management and the driver comfort. The cabinet will provide the required level of protection IP54 or better. The planned position of the pneumatic safety switch is marked with a red circle. The planned position of the electric safety-stop is marked by a red hexagon [9].

In the following Figure. 7 is shown the concept. The first two concepts also participated in the competition [10].



Fig. 7. Designed pneumatic cars in last three years

**Conclusions.** For the last three years the Department of Robotics has taken an active part in the international competition in pneumatic vehicles. This year the students have created the third concept of the pneumatic car. The first two concepts also took an active part in the competition. The last concept of the pneumatic car has been developed on the basis of the experience gained for the first two years.

This article describes one of the main parts of a pneumatic vehicle. The car has been designed to meet the requirements of the competition. One of the main parts of the vehicle design is the modeling of the frame to ensure safety requirements in case of accidents. As this car is a students' project, it could not be completed due to the ongoing Covid-19 pandemic. This proposed vehicle will be built soon when students return to the department.

**Acknowledgements.** This article was created with the support of the project KEGA: 010TUKE-4/2020 - Introduction of new knowledge and innovative approaches to the process of robotics training in accordance with Industry 4.

### References

1. Retrieved from [https://en.pneumobil.hu/pneumobile\\_2020/announcement\\_and\\_rules](https://en.pneumobil.hu/pneumobile_2020/announcement_and_rules).
2. Hajduk, M., Tuleja, P. "Základy pneumatických mechanizmov I.: Výroba, úprava a rozvod stlačeného vzduchu a vákua", Technická univerzita v Košiciach, Košice 2013, ISBN 978-80-553-1605-5.
3. Palko, M.: *Návrh experimentálneho vozidla poháňaného stlačeným vzduchom*. Technická univerzita v Košiciach. Košice 2018.
4. Lesiv, I.: *Návrh elektropneumatického riadenia úsporného pohonu pre projekt Pneumobil*. Technická univerzita v Košiciach. Košice 2020.
5. Shaimardanov, A.-S.: *Návrh úspornej pneumatickej pohonovej jednotky pre projekt Pneumobil*. Technická univerzita v Košiciach. Košice 2020.
6. Marcinko, P., Palko, M., Hajduk, M.: *Automobile with pneumatic engine*. 2018. In: Technical Sciences and Technologies. - Černihiv (Ukrajina): Chernihiv National University of Technology Roč. 13, č. 3 (2018), s. 55-60 [print]. ISSN 2411-5363.
7. Horvat, O.: *Návrh podvozovej skupiny pre long-distance disciplínu v projekte Pneumobil*. Technická univerzita v Košiciach. Košice 2020.

8. <https://store.arduino.cc/arduino-mega-2560-rev3>.
9. Solárik, R.: *Návrh motora pre pneumobil 2019*. Technická univerzita v Košiciach. Košice 2019.
10. Retrieved from <https://kosicednes.sk/zaujímavosti/strojari-z-tuke-vyrobili-prve-slovenske-auto-na-stlaceny-vzduch>.

UDC 621.941-229.3:621.822.172

Пітер Марцінко, Мікулаш Гайдук

## АВТОМОБІЛЬ НА СТИСНЕНОМУ ПОВІТРІ, ПНЕВМОБІЛЬ 2020

**Актуальність теми дослідження.** Проблема розробки пневмомобіля є дуже актуальною, оскільки сьогодні на-вколишньому середовищу загрожують різні викиди, вироблені автомобілями. Необхідно знайти її рішення. В даний час вже існують різні альтернативи двигунам внутрішнього згорання, і одна з них – це двигуни, що працюють на стиснутому повітрі.

**Постановка проблеми.** Основна мета - створити автомобіль, що працює на стисненому повітрі. Першочергова мета - створити рамку, що відповідає розмірам, визначеним змаганнями.

**Аналіз останніх досліджень і публікацій.** В останні роки компанія Aventics організувала змагання з перегонів на пневмомобілях. Протягом останніх тринадцяти років і до тепер ці перегони очолює компанія Emerson. Цей авто-мобіль мав бути представленим у всіх номінаціях конкурсу. Ми займаємося цією проблемою в Словаччині вже третій рік, і це наша третя модель.

**Виділення недосліджених частин загальної проблеми.** У цій статті описується автомобіль, який приводиться в рух стисненим повітрям, і більш детально описується використана рама та її особливості.

**Постановка завдання.** Метою даного дослідження є аналіз пневмомобіля, його частин і деталей, опис виготовленої рами і її властивостей. Відповідна рама була виготовлена за умов, визначених конкурсом Emerson.

**Виклад основного матеріалу.** Аналіз проводиться виходячи з умов конкурсу. Ці умови визначаються максимальними і мінімальними габаритами автомобіля. Виходячи з цих умов, була спроектована рама та попередньо піддана аналізу FEA - МКР. Опис корпусу наведено нижче.

**Висновки відповідно до статті.** У цій статті описується конструкція пневмомобіля для змагань. Змагання орієнтовані на автомобілі, що працюють на стиснутому повітрі. Ці пневмомобілі розробляються бакалаврами і студентами інженерних спеціальностей. Конструкція цього автомобіля пройшла первинний огляд, який схвалили організатори конкурсу.

**Ключові слова:** стиснене повітря; пневмобіль; рама.

Рис.: 7. Бібл.: 10.

**Peter Marcinko** – assistant professor, Technical university in Kosice, Faculty of Mechanical Engineering, Institute of Automatization, Mechatronics and Robotics, Department of Robotics, (Komenskeho Park 8, 042 00 Kosice, Slovakia).

**SCOPUS Author ID:** 57200138054

**E-mail:** peter.marcinko@tuke.sk

**Mikulas Hajduk** – prof., Eng., PhD, Professor, Technical university in Kosice, Faculty of Mechanical Engineering, Institute of Automatization, Mechatronics and Robotics, Department of Robotics, (Komenskeho Park 8, 042 00 Kosice, Slovakia).

**Scopus Author ID:** 35826618400

**E-mail:** mikulas.hajduk@tuke.sk