

UDC 621.8

DOI: 10.25140/2411-5363-2020-4(22)-35-41

Jan Semjon, Lubomir Hriz, Martin Kocan, Alexander Voronko

DESIGN OF ASSEMBLY ROBOTIZED WORKPLACE

Urgency of the research. Replacing manual assembly with robotic workplaces increases the productivity and quality of assembly. Operator at the robotic workplace is necessary to control of the operation processes and adding components to the tanks and removing the finished parts from the appropriate box. This allows the operator to be used parallel for other activities within the production line. The cost of building a robotic workplace is relatively low compared to the rising cost of human labor. This creates a precondition for maintaining the competitiveness of the company.

Target setting. The aim was to design a functional assembly robotic workplace using an affordable SCARA robot from the Dobot company. The designed robotic assembly workplace, after implementation made, should increase assembly productivity.

Actual scientific researches and issues analysis. Increasing productivity without the use of automated or robotic systems is currently not possible. This leads to the spread of robotic applications even in the assembly of relatively simple parts, which are produced in several modifications.

Uninvestigated parts of general matters defining. Improving the quality of assembly production with the using of robotic workplaces is required not only in the company that carries out assembly, but especially from customers of manufactured parts. It leads to reduced in the proportion of human labor to a minimum.

The research objective. The aim was to design such a robotic workplace that would make it possible to relieve a person from monotonous work. Another goal was to increase the quality of pressing two parts and, above all, to increase labor productivity by at least 10%. At the same time, to ensure a minimum participation of the operator at the robotic workplace, so that he can be used for other activities within the assembly line.

The statement of basic materials. The spread of affordable industrial robots with an open architecture has an increasing tendency in larger as well as smaller operations. This leads to the creation of small robotic cells, which can be relatively easily rebuilt according to current needs in the workplace. The article describes the design of a robotic assembly workplace using a SCARA robot. The workplace is designed for the assembly of two parts "A and B", while part "A" is the same for all three final products. The types of connections differ only in their length in three dimensions. A vibrating hopper was used at the workplace for feeding components "A". A special feeder was designed for the feeding of components "B", enabling the feeding of all three lengths of component "B". An automatic pressing station was designed for the assembly of components. The operator of the facility checks the activity of the workplace at regular intervals. It is only necessary to refill the components in the hopper twice per shift.

Conclusions. In this work shows the solution to an important technical problem. The functional of assembly robotic workplace using an affordable SCARA robot from the Dobot company were designed. The designed workplace allows pressing 3 types of assemblies, which differ from each other only by the total length of one component. The designed robotic workplace made it possible to increase productivity by 12% and reduce the presence of the operator to the minimum possible level.

Key words: robot SCARA; programming; assembly; robotic workplace.

Fig.: 10. References: 7.

Problem definition. Robotic technology already affects all aspects of work and home. Robotics has the potential to positively transform lives and work practices, increase efficiency and safety, and provide increased levels of service. Even more, robotics is set to drive technology that supports a whole new generation of autonomous devices and cognitive accessories that, thanks to their learning abilities, work seamlessly with the world around them, thus providing the missing connection between the digital and physical worlds. Robotics is already a key driver of competitiveness and flexibility in large manufacturing industries. Without robotics, many successful industries would not be able to compete with the current pace of production technology development and the growing demand for products. Robotics is becoming increasingly relevant for smaller industries [1].

The process of robotization is done in order to replace the manual work of man, during more difficult physical manipulation operations. Furthermore, also due to the mental health of a person during monotonous work. The use of industrial robots automates processes throughout the production line to save time and money. Industrial robots reduce waste and produce higher quality products with continuous precision. Robots can handle even the most demanding and dangerous production processes. Every industrial robot application requires a unique tool at the end of the arm, a specific reach, a payload and flexibility. The automotive industry has been one of the fastest growing industries, with industrial robots being the most widely used for a long time. Robots are used in almost all parts of automotive manufacturing and remain one of the most automated supply chains in the world. Industrial robots can significantly improve product quality. Applications are

performed with accuracy and excellent repeatability in every job. This level of reliability can be difficult to achieve in other ways. The disadvantage associated with the integration of robots into the company is the significant initial costs. Continuous maintenance requirements may be added to the total cost. Based on the mechanical configuration, serial industrial robots can be divided into the following main groups: Cartesian robots (TTT), cylindrical robots (RTT), polar (spherical) robots (RRT), articulated robots (RRR) and robots of the SCARA type (RRT or TRR). In addition to the mechanical configuration, industrial robots can also be categorized on the basis of motion control, power supply method and other physical characteristics [1; 2].

The SCARA (Selective Compliance Assembly Robot Arm) robots have a working space in the shape of a ring and consist of two parallel rotary joints that ensure movement in one selected plane. The swivel joints are positioned vertically, so that the end effector attached to the arm moves horizontally. SCARA robots specialize in sideways movements and are mostly used in the food, medical and assembly industries. It is designed primarily for small and fast tasks. SCARA robots can move faster and integrate more easily than cylindrical and Cartesian robots. Compared to robots with six degrees of freedom, it is not that flexible, but is much faster and has higher repeatability accuracy. Therefore, they are mostly used for pick-and-place operations. The inverted kinematic structure (TRR) gives it further possibilities to apply itself to specific tasks, where the vertical displacement in the Z axis is performed by the whole arm attached to the base. The disadvantage of such an arrangement is the poorer handling ability in the direction of the "Z" axis, if there are obstacles in the working space and it is necessary to insert the component into a deeper cavity [3].

Current status in workplace. At present, the assembly workplace has been designed as a manual workplace, where one operator works with a small lever press. Two components are connected at this workplace. The first is component "A". It is a plastic rod and has three size variants, namely 192, 140 or 90 mm in length. The other dimensions are the same. Component types "B" is a metal roller that is pressed onto component "A". On the left side of Fig. 1 the dimensions of component A and on the right side of component B are seen.

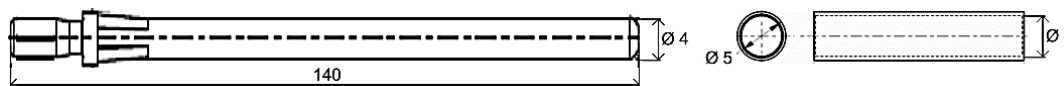

Fig. 1. Dimensions of components A and B

The work procedure in the manual workplace can be divided into three basic steps. In the first step, component A is inserted into the opening of the support of the pressing device. In the second step, component B is inserted. It is inserted into the upper press tool. Subsequently, the third step takes place, namely the insertion of the support under the press and the pulling of the lever, by means of which the two components are pressed together. The last operation that the operator must perform is to remove the moulded assembly from the support. Fig. 2 shows all three basic steps of the process. The first figure on the left shows the process of inserting component A. The figure in the middle shows the insertion of component B into the upper pressing tool. The picture on the right shows an example of pressing components on a hand press.



Fig. 2. Manual assembly process

Proposal of robotized workplace. The proposed robotic workplace has a reserved maximum floor plan measuring of 1550×850 mm. To reduce the built-up area, the workplace will be placed on a work table at a height of 1000 mm, so that it is possible to use the space under the table to store the necessary equipment for the operation of the workplace. The proposed workplace will consist of the following basic parts: a robotic arm (SCARA type robot), a vibrating hopper for components B, a hopper for components A and a pressing station. The principle of operation of the workplace is based on the work procedure used in manual assembly. The task of the deployed robot is to replace a human in the work process, so that his intervention consists only in adding individual components to the magazines. Fig. 3 shows a design of the arrangement of individual parts on the workplace table.

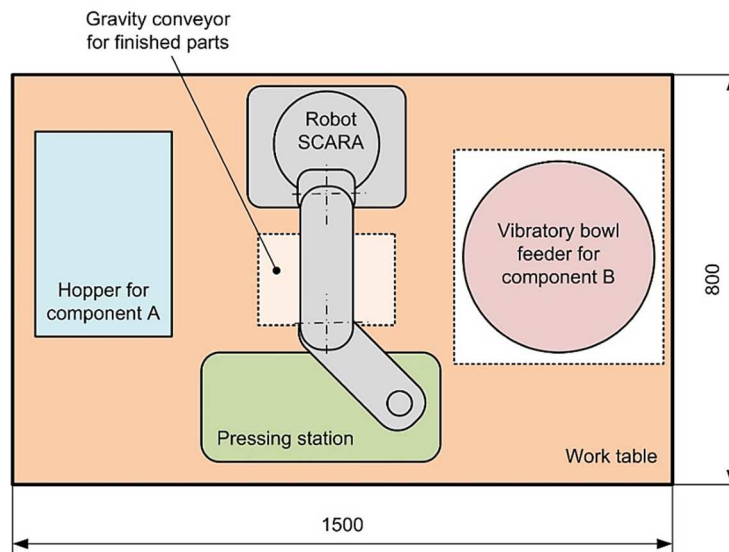

Fig. 3. Arrangement of a robotized workplace

A robot of the SCARA Dobot M1 type was chosen for the needs of handling individual components and the finished part. The reason for choosing a robot was mainly its relatively low price on the market, as well as its parameters and the size of the workspace. The load capacity of the robot is 1.5 kg and the repeatable accuracy +/- 0.02 mm. Fig. 4 shows a view of Dobot M1 and its working space [4].

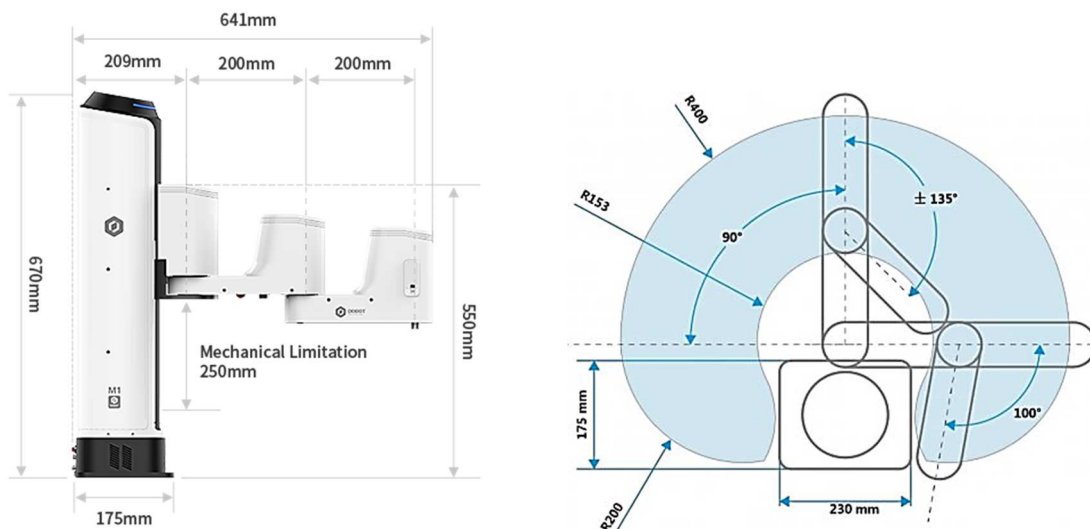

Fig. 4. Robot Dobot M1 [4]

A two-finger gripper from Schunk under the designation MGP 40 was chosen as the end effector for the robot. It is a two-jaw, pneumatic, parallel gripper with flat guide surfaces of the basic jaws. It can be used to grip and move small to medium-sized workpieces in low-contaminated environments, such as assembly lines, laboratories and the pharmaceutical industry. The recommended weight of the handled part is up to 0.55 kg and the pressing force has a value of 110 N [5]. It was necessary to design fingers for the selected effector, which were then printed on a 3D printer. The finger has a circular contact surface with a radius of 3 mm. Component B has the same radius. Component A has a radius of 3.5 mm, which also ensured a relatively good grip. In Fig. 5 a sketch of the proposed finger is displayed.

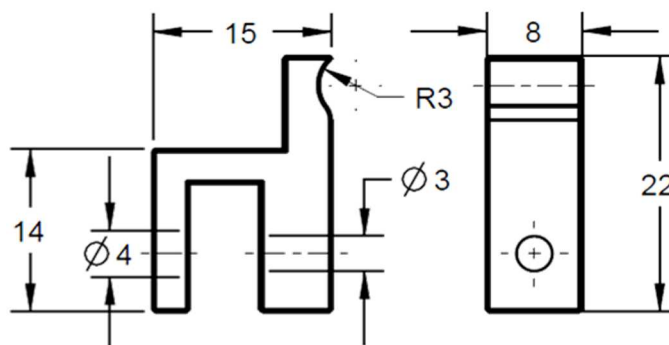

Fig. 5. Basic finger dimensions

The pressing station is used to store component A, then component B. After securing the components in position, the components are pressed. After the pressing is completed, the finished part will be tilted into the gravity trough. Fig. 6 contains a nest (1) for placing component A by means of a robot. Furthermore, the pressing - pneumatic piston (2), which is equipped at the end of the piston rod with a housing (3), into which the robot inserts component B. Another pneumatic piston with locking (4) prevents component A from falling out of the nest during its pressing. After pressing and releasing the finished product, the inclined platform (5) is raised by means of a pneumatic piston (6) located below it. The finished piece slides on this platform and falls through an opening in the workplace table directly into the prepared box.

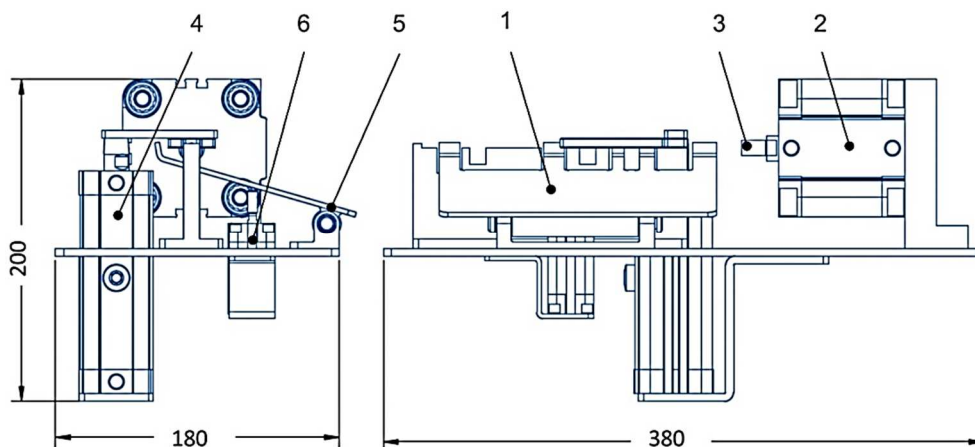

Fig. 6. Pressing station

A vibrating feeder from Hensle, type EMSE 40, was selected for the transport of small components B, which is characterized by a fill weight of up to 20 kg [6]. A pull-out hopper has been designed to supply the workplace with A components. The V-shaped hopper was made of polyurethane and the middle catcher was made of sheet steel. The hopper is provided on both sides with three grooves into which the separating screen is inserted, Fig. 7.

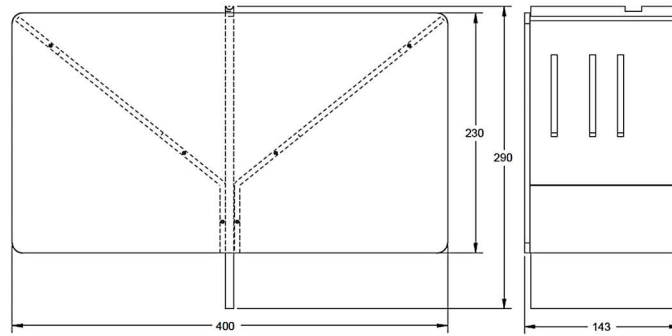

Fig. 7. V-shaped hopper

The separating shield is placed in the appropriate groove, according to the length of the currently pressed component A. The principle of operation is based on the use of gravity and pneumatic extension of the catcher. When the catcher is in the lower position, the components A are stored in the container fitted with the separating shield in an oriented manner. Subsequently, the robot picks up component A and moves it to the pressing station. In Fig. 8 is a view of a container for components A.

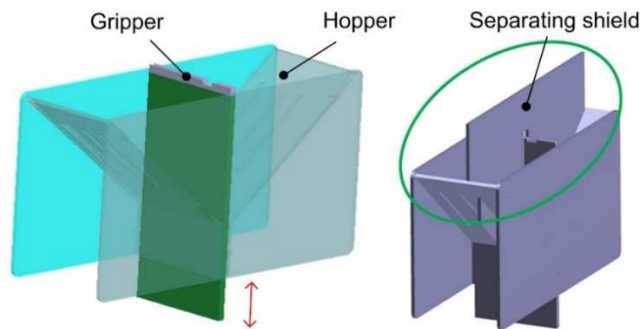

Fig. 8. Magazine for components A

The frame of the designed workplace is made of welded steel closed profiles measuring 50×50×3 mm. The worktop is made of aluminium plate 20 mm thick to maintain sufficient rigidity. Then it is screwed to the workplace frame.

The view of the designed workplace in 3D view is shown in Fig. 9. The height of the workplace is 1608 mm. The workplace shown will be additionally equipped with a protective cover made of clear polycarbonate. The construction of the protective cover will be realized from the use of system aluminium profiles of 30×30 mm. There will be two doors in the front to allow operator and maintenance access. It will be possible to place a box under the workplace table into which the finished parts will fall out.

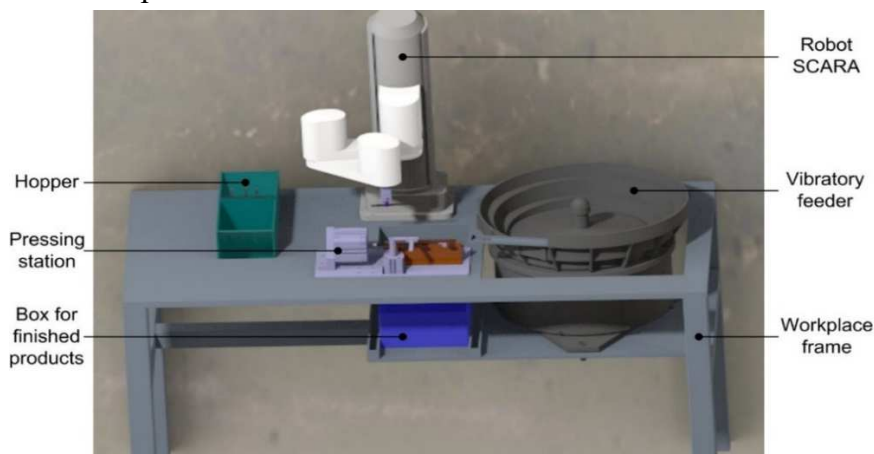

Fig. 9. View of the workplace in 3D view

The design of the workflow and its debugging was implemented in the off-line environment RoboDK [7]. The used SCARA robot was selected from the environment database and then 3D models of other workplace components were added. In addition to checking the mutual overlap of the robot's workspace and individual components of the workplace, a complete program design and its connection with the Simatic S7-1200 control PLC was implemented. In Fig. 10 is a view of a workplace in a RoboDK environment.

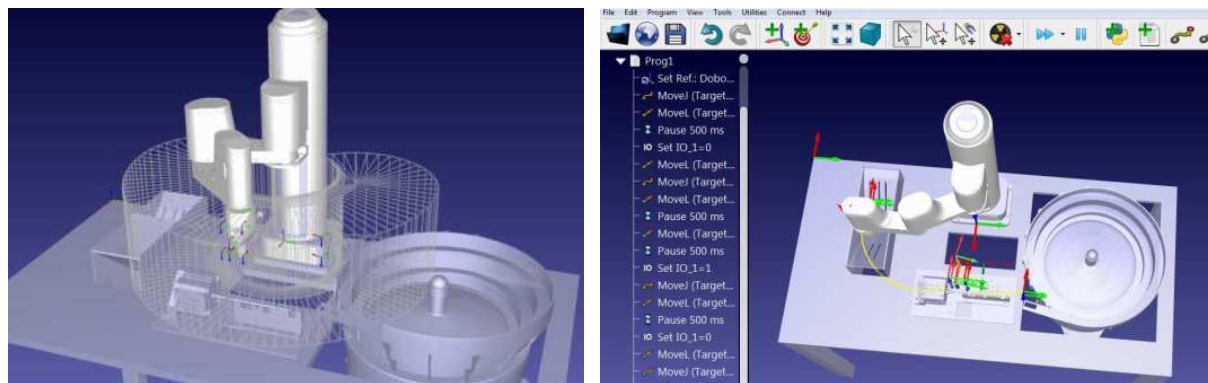

Fig. 10. Workplace in RoboDK environment

The workplace was then equipped with a camera, which also made it possible to monitor the success of the pressing of parts.

Conclusions. This article describes how to replace the monotonous human assembly activity with a SCARA robot. The designed workplace allows pressing 3 types of assemblies, which differ from each other only by the total length of one component. When changing the component type, operator intervention is required to select the correct component length on the HMI panels. In addition, it empties the container for components A and then moves the partition screen to the desired groove. Of course, it is also necessary to empty the box of finished products.

The engineering design of the robotic workplace reduced the time required for the assembly of components by 12%. The operator of the equipment fills the magazine and inspects the workplace every 4 hours, while the rest of the working time is devoted to work at another workplace of the production line.

Acknowledgements. This article was created thanks to the KEGA project support: 010TUKE-4/2020 - Implementation of new knowledge and innovative approaches to the process of teaching robotics in line with Industry 4.

This paper was published in cooperation with company KYBERNETES s.r.o. within the project "Research and development of the ECOGI product at KYBERNETES", ITMS Code of Project: 313012Q955.

References

1. Kolibal, Z., et al. (2016). Roboty a robotizované výrobní technologie. Brno: VUTIUM, 2016. 788 p. ISBN: 978-80-214-4828-5. [in Czech]
2. Hajduk, M., et al. (2015). Robotika - Robotická technika, 1. vyd - Košice : TU, Sjf – 2008, 84 s., ISBN 978-553-0034-4. [in Slovak]
3. Chandrasekaran K., Djuric A., ElMaraghy W.H. (2012). Selection Catalogue of Kinematic Configuration for Pick and Place Application. In: ElMaraghy H. (eds) Enabling Manufacturing Competitiveness and Economic Sustainability. Springer, Berlin, Heidelberg. https://doi.org/10.1007/978-3-642-23860-4_6.
4. Dobot M1. Retrieved from <https://www.dobot.cc/dobot-m1/product-overview.html>.
5. Schunk. Retrieved from https://schunk.com/de_en/gripping-systems/product/2422-0340012-mpg-40.
6. HENSLE. Retrieved from https://www.hensle-zufuehrtechnik.de/wp-content/uploads/2016/02/eng_katalog_hensle.pdf.
7. RoboDK. Retrieved from <https://robotdk.com>.

УДК 621.8

Ян Семйон, Любомір Гриз, Мартін Кочан, Олександр Воронько

ПРОЄКТУВАННЯ РОБОТИЗОВАНОГО СКЛАДАЛЬНОГО РОБОЧОГО МІСЦЯ

Актуальність теми дослідження. Заміна ручного складання роботизованими робочими місцями підвищує продуктивність та якість складання. Оператор на роботизованому робочому місці необхідний для контролю робочих процесів, додавання компонентів до резервуарів та виїмання готових деталей із відповідного контейнера. Це дозволяє паралельно використовувати оператора для інших видів діяльності на виробничій лінії. Вартість створення роботизованого робочого місця відносно невисока порівняно зі зростанням вартості людської праці. Це створює передумови для збереження конкурентоспроможності компанії.

Постановка проблеми. Завдання полягає в розробці робочого місця для складального робота з використанням доступного робота SCARA від компанії Dobot. Спроектване роботизоване складальне робоче місце після впровадження має підвищити продуктивність складання.

Аналіз останніх досліджень і публікацій. Підвищення продуктивності без використання автоматизованих або роботизованих систем на даний час неможливо. Це призводить до поширення роботизованих додатків навіть при складанні відносно простих деталей, які випускаються в декількох модифікаціях.

Виділення недосліджених частин загальної проблеми. Підвищення якості складального виробництва з використанням роботизованих робочих місць потрібно не тільки в компанії, що здійснює складання, але особливо замовниками вузлів, що виготовляються. Це призводить до скорочення частки людської праці до мінімуму.

Постановка завдання. Завдання полягало у створенні такого роботизованого робочого місця, яке дозволило б позбавити людину від монотонної праці. Іншою метою було підвищення якості пресування двох деталей і, перш за все, підвищення продуктивності праці не менше ніж на 10 %. Водночас необхідно забезпечити мінімальну участь оператора на роботизованому робочому місці робота, щоб він міг виконувати інші дії на складальній лінії.

Виклад основного матеріалу. Поширення доступних промислових роботів з відкритою архітектурою має тенденцію зростання як в великих, так і в дрібних операціях. Це призводить до створення невеликих роботизованих елементів, які можна відносно легко перебудувати відповідно до поточних потреб на робочому місці. У статті описана конструкція роботизованого складального робочого місця з використанням робота SCARA. Робоче місце призначене для складання двох частин «А і В», а частина «А» однакова для всіх трьох кінцевих виробів. Типи з'єднань розрізняються тільки довжиною трьох розмірів. На робочому місці застосовувався вібраційний бункер для подачі компонентів «А». Для подачі компонентів «В» було розроблено спеціальний пристрій подачі, що дозволяє завантажувати компоненти «В» всіх трьох довжин. Для складання компонентів була розроблена автоматична пресова станція. Оператор установки регулярно перевіряє активність робочого місця. Необхідно всього лише двічі за зміну додавати компоненти в бункер.

Висновки відповідно до статті. У даній роботі показано вирішення важливої технічної проблеми. Розроблено функціонал роботизованого складального робочого місця з використанням доступного робота SCARA від компанії Dobot. Спроектване робоче місце дозволяє пресувати 3 типи вузлів, які відрізняються один від одного лише загальною довжиною одного компонента. Розроблене роботизоване робоче місце дозволило збільшити продуктивність на 12% і скоротити присутність оператора до мінімально можливого рівня.

Ключові слова: робот SCARA; програмування; складання; роботизоване робоче місце.

Рис.: 10. Бібл.: 7.

Jan Semjon – Associate Professor, Technical University of Kosice, Faculty of Mechanical Engineering, Department of production systems and robotics (Park Komenskeho 8, 04200 Kosice, Slovakia).

E-mail: jan.semjon@tuke.sk

Scopus Author ID: 55571411200

ORCID: <https://orcid.org/0000-0002-9076-7808>

Lubomir Hriz – Student of engineering studies, Technical University of Kosice, Faculty of Mechanical Engineering, Department of production systems and robotics (Park Komenskeho, 04200 Kosice, Slovakia).

E-mail: lubomir.hriz.student@tuke.sk

Martin Kocan – Student of Ph.D studies, Technical University of Kosice, Faculty of Mechanical Engineering, Department of production systems and robotics (Park Komenskeho 8, 04200 Kosice, Slovakia).

E-mail: martin.kocan.student@tuke.sk

Alexander Voronko – Designer, KYBERNETES, s.r.o. (Omska 14, 040 01 Kosice, Slovakia).

E-mail: alexander.voronko@kybernetes.sk

ORCID: <https://orcid.org/0000-0003-0950-2173>