

UDC (07)621.7.621.8

DOI: 10.25140/2411-5363-2019-4(18)-68-73

Peter Tuleja

## MEASURING METHODOLOGY AND PARAMETRIC TESTS OF ROTARY POSITIONING TABLE

**Urgency of the research.** The use of positioning tables as peripheral devices for production or robotic technology is an urgent need for today's automated operations. Since their task is to extend the user's possibilities in the workplace, their design and control method and, last but not least, the technical parameters must correspond to the level of machine tools and robots.

**Target setting.** The aim of this paper was to approach in a real case the methodical approach to the determination of key parameters of rotary positioning units intended for manufacturing technology and robotics. The tests carried out on the real representative gave an answer to the question of the applicability of the selected methodology for measuring selected parameters of the rotary uniaxial positioning table.

**Actual scientific researches and issues analysis.** Research in this area consisted in designing a methodological basis for obtaining relevant data useful for evaluating the technical level of the prototype being measured.

**Uninvestigated parts of general matters defining.** In the paper and basically also in the performance of the tests on the VAPOS module it was not possible to perform full parametric tests for some problems related to the technical design of the sample (prototype), therefore the proposed measurement methodology focused rather on the issue of making and justifying the use of some building elements of the table.

**The research objective.** The aim of the project and the article was to verify the validity of the methodology used and to verify the suitability of the type of reducer used in such a technique.

**The statement of basic materials.** The basic materials for the creation of the article were processed data from sample measurement at our department. Some of the data contained in the measurement protocol was not difficult to disclose because it is the know-how of the department and the sponsor.

**Conclusions.** The conclusions of the paper and the project show the suitability of the chosen methodology and the results from measurements according to this methodology were used for further improvement of the design of the rotary table at the manufacturer and in the development of new types of reducers of their supplier.

**Keywords:** methodology; rotary table; accuracy; indexing; parametric test.

Fig.: 13. Table: 1. References: 9.

**Introduction.** In production in robotic plants, the equipment of the robotic structure is greatly limited by the complexity of application of the workplace. In order to achieve all the required positions of the working tool (eg welding torch or welding tongs) (eg in arc welding or spot welding), the workstation must be equipped with a suitable peripheral device. Such a device serves as a tool to extend the application possibilities of the workplace.

In current technical practice, positioning rotary modules are increasingly used in machine tools and robotized workplaces, both in the position of the next working axis of the machine / robot and in the position of the positioning device for positioning the machine / robot tooling.

Positioning devices designed for machine tools are offered by almost all leading companies in the manufacturing machine segment (eg Tsudakoma Corp., Japan, Nikken Comp., Japan and others), fig. 1. Units of this type shall be manufactured in single, double and triple versions.



Fig. 1 Rotary tables [7],[8],[9]

**Rotary table tests.** Parametric tests carried out on such devices depend on the intended use. These tests are precisely defined in international (ISO 230-2 / 1997 - only rotary and linear axes in uniaxial design) and national (JIT, DIN) standards. The standard measurement methodology resulting from the norms is to some extent adapted by individual manufacturers according to the application deployment of such a unit.

TECHNICAL SCIENCES AND TECHNOLOGIES

**Types of tests.** Tests performed on a rotary table can be divided into two basic groups [6]:  
 (a) *tests of geometric accuracy* achieved in the manufacture of module components;  
 (b) *tests for accuracy and repeatability of the module stop* at the programmed position of the rotary module.

Geometric accuracy of execution of individual module components consists of a total of 8 measurements of parameters, table, ultimately determining its applicability.

Table

*Geometrická presnosť vyhotovenia stola [2]*

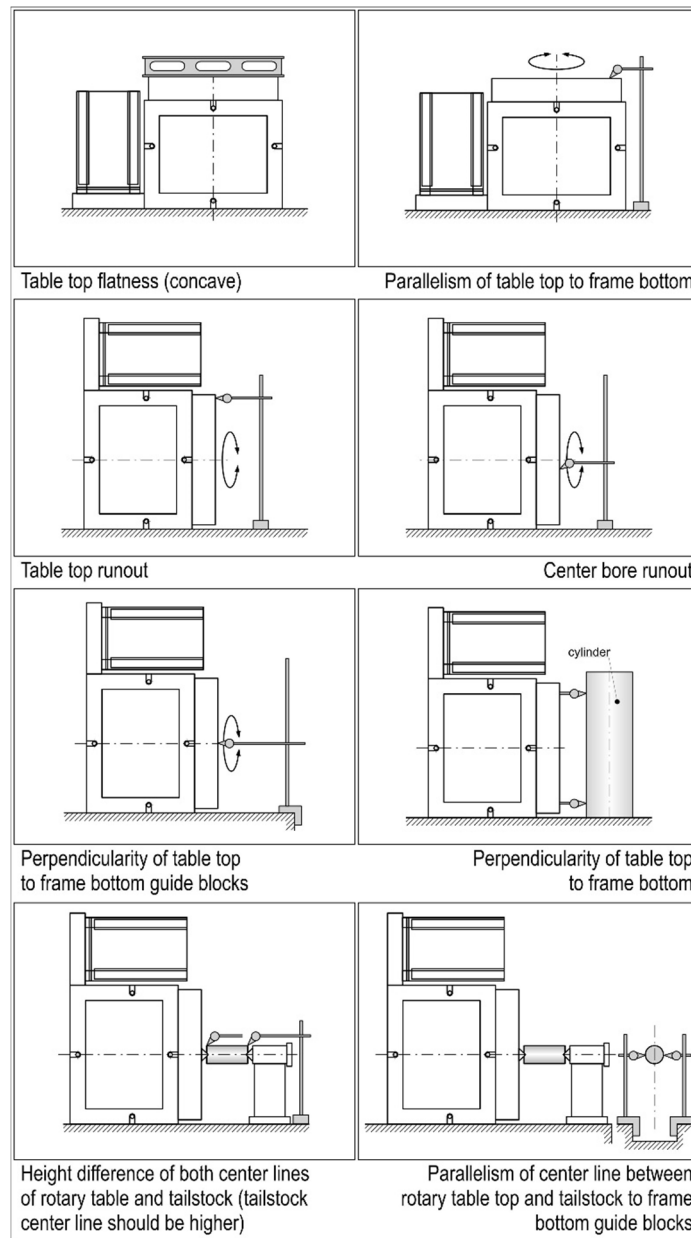

The basis for making these measurements is the methodology for verifying the geometrical parameters of machine tools (the so-called Schlesinger methods).

The measurement chain for these tests shall consist of an odometer and a standard reference body, Table 1.

Given the accuracy and application of the tables, it is necessary to use gauges with the appropriate accuracy class (min. 0.01 mm).

Repeatable stopping accuracy in the programmed position (so called indexing) is based on repeated stopping of the module table at the programmed point while measuring the absolute repeated inaccuracy of the module stopping in this position [1, 3].

**Rotary table VAPOS 300 [5].** A single-axis rotary, continuously controlled positioning module with SIEMENS Simudrive 611 control was used to create the methodology and perform tests to verify it. The TWINSPIN TS240 / 121 reducer (manufactured by SPINEA, Slovakia) was used by the manufacturer to reduce the nominal speed of the servomotor.

Figure 2 shows a representation of the rotary module with its principle (arrangement of functional parts) as well as some of its parameters.

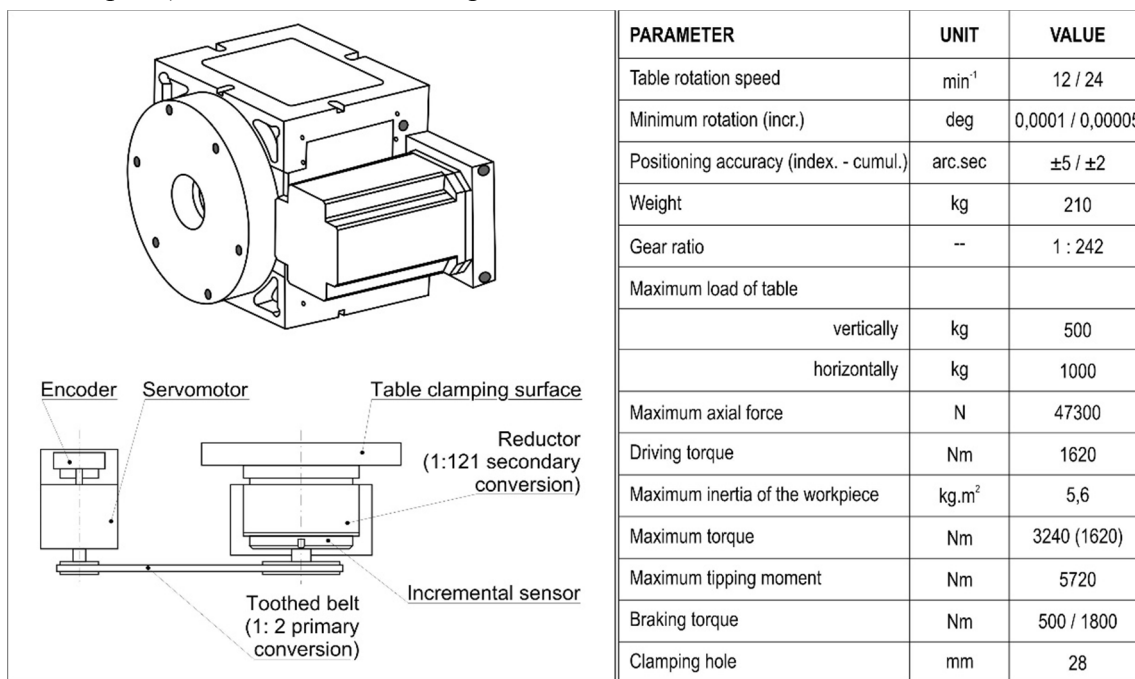

Fig. 2. Rotary table VAPOS 300 [5]

**Tests of VAPOS 300 rotary table.** The positioning table was subjected (according to customer requirements) to some kinematic tests, indexed positioning accuracy and partial frequency analysis of the behavior of the mechanical part of the table was performed. Tests were carried out with no load and technological load.

The technological load during the measurement was caused by the cutting process when machining the test piece on a mechanical cantilever milling machine, fig. 3.

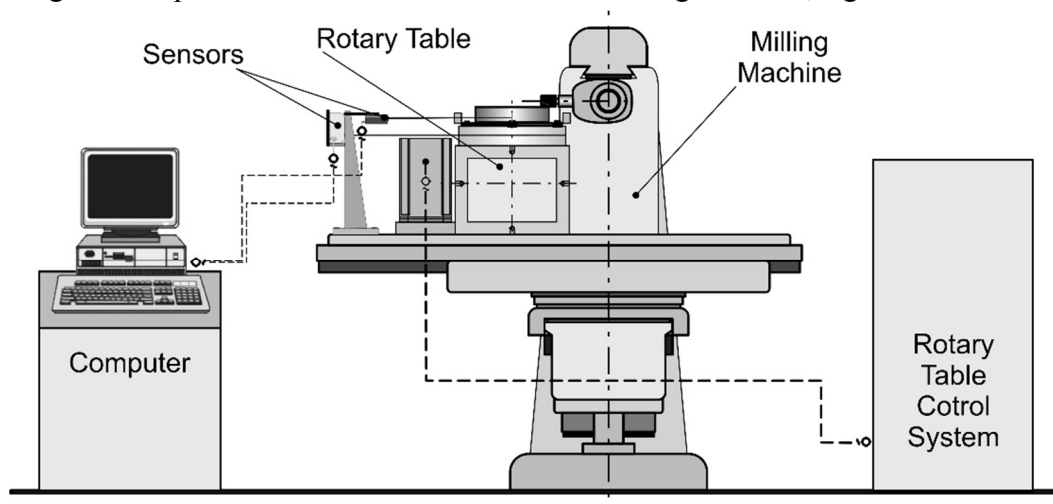

Fig. 3. Measuring set (measuring string) Source: author

TECHNICAL SCIENCES AND TECHNOLOGIES

**a) Kinematic tests of rotary table**

In the kinematic tests of the table, the measurement of the path, speed and acceleration of the table was performed without load and at the technological load. Figures 4, 5 and 6 show graphical recordings of measured paths, speeds and accelerations without load. The measurement of the kinematic characteristics of the table was performed by the DSS-5L cable track sensor with the MIS-3 measuring card and the ProMeS evaluation software.

Figures 7, 8 and 9 show graphical records of the measured course of the path, speed and acceleration of the load table.

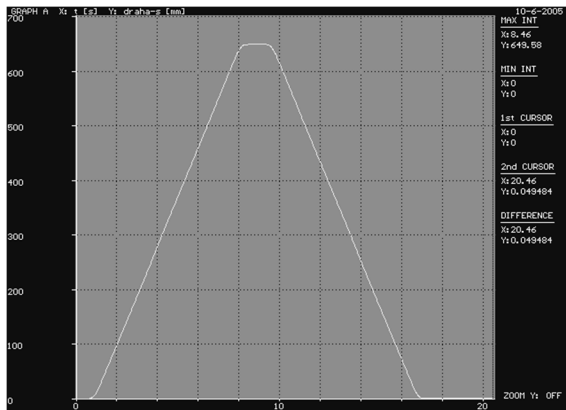

Fig. 4. Table path (no load)

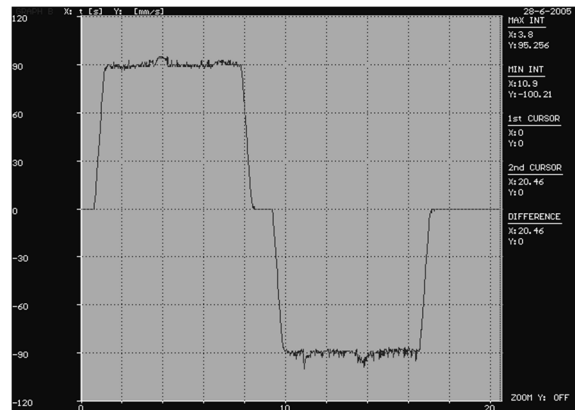

Fig. 5. Table speed (no load)

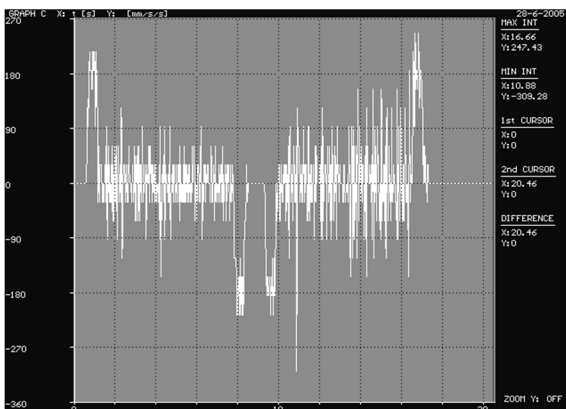

Fig. 6. Table acceleration (no load)

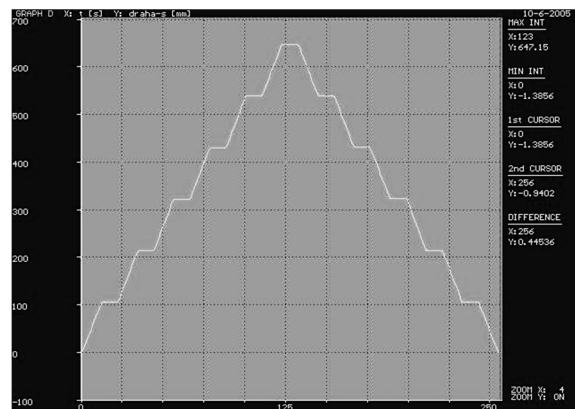

Fig. 7. Table path (with load when indexing)

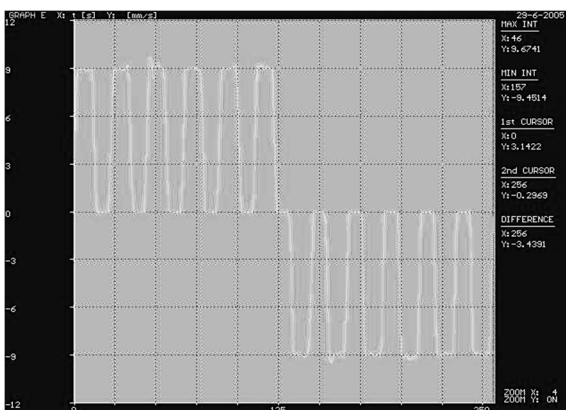

Fig. 8. Table speed (with load when indexing)

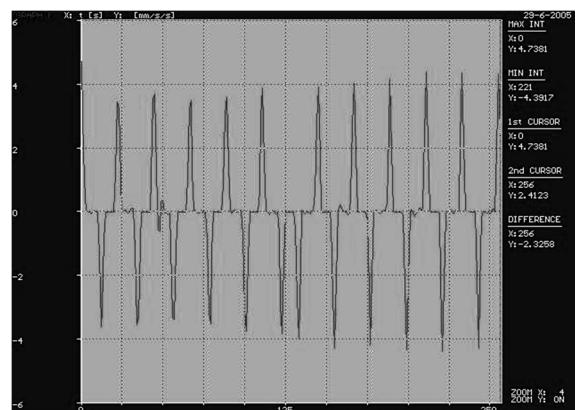

Fig. 9. Table acceleration (with load when indexing)

**b) Table tests of accuracy when indexing**

The indexed table accuracy test methodology is described (for uniaxial tables) by the international standard ISO 230-2 / 1997. Every company producing rotary modules is bound by this methodology. This consists of programming the rotary module for repeated stopping at the measured points, and deviations from the programmed value are read and recorded. Measurements are made at eight or sixteen points while turning the table CW and CCW. Measurement of deviations is usually performed by a precision rotary encoder (incremental, encoder, etc.). A graphical representation of the deviations measured according to this methodology is shown in Fig. 10.

The VAPOS table measurement methodology was carried out in a modified version, as the rotary module delivered for testing was not equipped with the necessary sensory equipment and the positioning surface did not have the necessary parameters (it was a prototype).

We chose the aiming system of targets fixed in the positions of the clamping holes (6xM16) with the laser sensor ZX-LD 100 from OMRON.

A graphical representation of the course of the measured deviations is shown in Fig. 11.

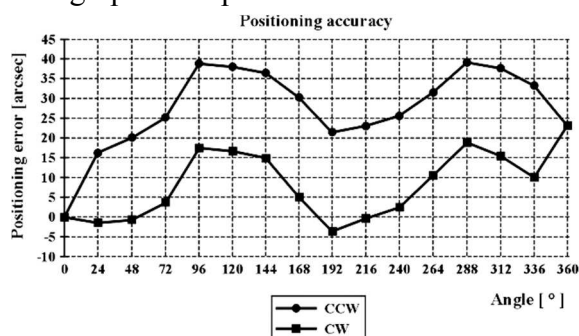

Fig. 10. Positioning accuracy CCW/CW

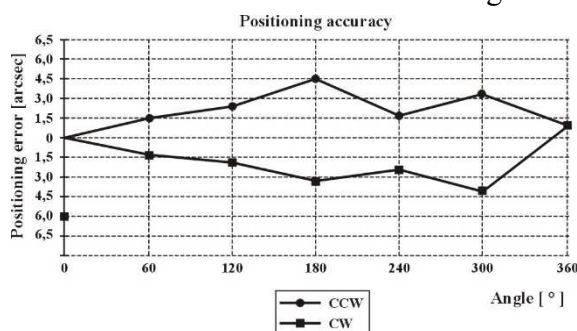

Fig. 11. Modified positioning accuracy CCW/CW

**c) Table frequency analysis**

The rotary table vibrations were measured only in a tangential direction by the piezoelectric acceleration sensor (ADASH, Czech) at a radius of 128 mm from the center of the table rotation.

The table operation modes were identical to those loaded during the kinematic test and indexed positioning accuracy measurements.

The graphical waveforms of the measured table vibrations are shown in Fig. 12 and 13.

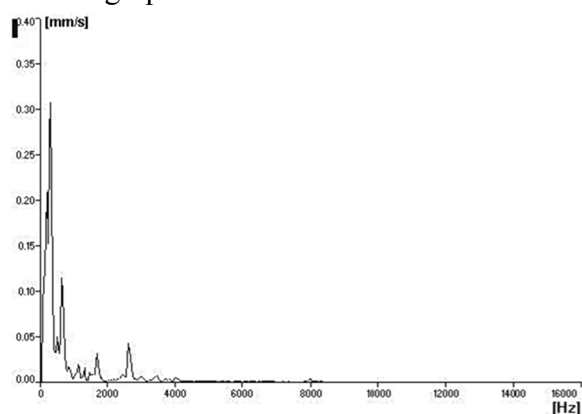

Fig. 12. Table frequency analysis (a)

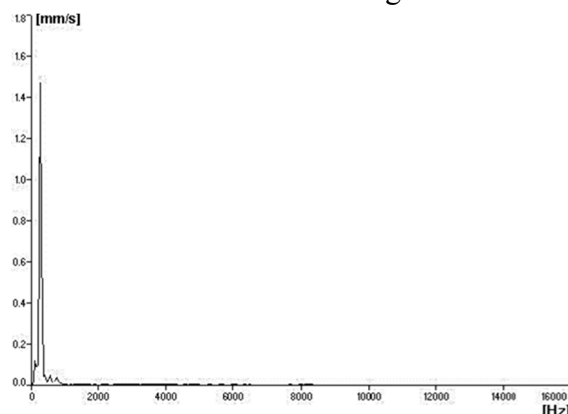

Fig. 13. Table frequency analysis (b)

**Conclusions.** Positioning rotary modules, as a tool for increasing technological parameters of production equipment performance, will continue to be increasingly used in technical and technological practice. their users.

**Acknowledgement.** *This contribution is the result of the project implementation: Re-search modules for intelligent robotic systems (ITMS: 26220220141) supported by the Re-search & Development operational Program funded by the ERDF.*

### References

1. ČSN ISO 230-2:1997. Zásady zkoušek obráběcích strojů – Část 2: Stanovení přesnosti a opakovatelnosti nastavení polohy v číslicově řízených osách.
2. Burkovič, J.: Spolehlivost, diagnostika, jakost. ES VŠB-TU, Ostrava 2001, ISBN 80-7078-838-9.
3. ČSN 20 0300:1994 část 9. Měření geometrické přesnosti obráběcích strojů.
4. OMRON: Company literature.
5. VAPOS: Company literature.
6. Zelko J. a spol.: Meranie v strojárstve, Alfa Bratislava 1973.
7. <http://www.haascnc.com>.
8. <http://www.tsudakoma.co.jp>.
9. <http://www.nikken-world.com>.

УДК (07)621.7,621.8

Петер Тулея

## МЕТОДИКА ВИМІРЮВАННЯ І ПАРАМЕТРИЧНІ ВИПРОБУВАННЯ ПОВОРОТНОГО ПОЗИЦІЙНОГО СТОЛУ

**Актуальність теми дослідження.** Використання позиційних столів в якості периферійних пристроїв для виробничих або роботизованих технологій є нагальною потребою для сучасних автоматизованих операцій. Оскільки їх завдання полягає в розширенні можливостей користувача на робочому місці, спосіб їх проектування та управління а також, що не менш важливо, технічні параметри повинні відповідати рівню верстатів і роботів.

**Постановка проблеми.** Метою даної роботи було наблизити в реальному випадку методичний підхід до визначення основних параметрів обертових позиційних вузлів, призначених для виробничих та роботизованих технологій. Випробування, проведені на реальному представнику, дали відповідь на питання про застосовність обраної методології для вимірювання вибраних параметрів поворотного одновісного позиційного столу.

**Аналіз останніх досліджень і публікацій.** Дослідження в цій галузі полягали в розробці методологічної бази для отримання відповідних даних, корисних для оцінки технічного рівня досліджуваного прототипа.

**Виділення недосліджених частин загальної проблеми.** У статті та в основному при виконанні випробувань на модулі VAPOS не вдалося виконати повні параметричні випробування для деяких задач, пов'язаних з технічним дизайном зразка (прототипу), тому запропонована методологія вимірювання була скоріше зосереджена на питанні складання та обґрунтування використання деяких елементів конструкції столу.

**Постановка завдання.** Метою проекту та статті було перевірити обґрунтованість використовуваної методології та перевірити відповідність типу редуктора, що використовується у такій техніці.

**Виклад основного матеріалу.** Основними матеріалами для створення статті були оброблені дані з вибіркового вимірювань у нашому відділі. Деякі дані, що містяться в протоколі вимірювання, було важко розкрити, оскільки це ноу-хау відділу та спонсора.

**Висновки відповідно до статті.** Висновки з цієї статті та проекту показують придатність обраної методології, а результати вимірювань відповідно до цієї методології використовувались для подальшого вдосконалення конструкції поворотного столу у виробника та при розробці нових типів редукторів їх постачальником.

**Ключові слова:** методика; поворотний стіл; точність; індексація; параметричне випробування.

Рис.: 13. Табл.: 1. Бібл.: 9.

**Tuleja Peter** – Eng., PhD, Assistant Professor, Technical university in Kosice, Faculty of Mechanical Engineering, Institute of Automatization, Mechatronics and Robotics, Department of Robotics (Komenskeho Park 8, 04200 Kosice, Slovak Republic).

**Петер Тулея** – помічник професора, кандидат технічних наук, Технічний університет Кошице (Komenskeho Park 8, 04200 Kosice, Slovak Republic).

**E-mail:** peter.tuleja@tuke.sk

**Scopus Author ID:** 55570858300