

СЕКЦІЯ 3. ГІДРАВЛІЧНІ ТА ПНЕВМАТИЧНІ СИСТЕМИ

УДК 621.

Vasil Ruzaikin, Associate Professor
Andrii Breus, Associate Professor
Olena Torosian, Senior Lecturer
Ivan Lukashov, assistant

National Aerospace University «KhAI», o.tarasyan@khai.edu

TWO-PHASE AMMONIA FLOW PARTICULARITIES IN TEES

Phase separation of a two-phase working fluid accompanies the thermal-hydraulic process in every system and device, with at least one T-junction used in a two-phase line. Adequate qualitative and quantitative prediction of phase separation in T-junction is critical for successful designing, e.g., refrigeration, thermal control, and fluid transport systems. Three simple T-junctions with different inlet and side diameters were tested in the horizontal position on two-phase ammonia at a saturation level of $40\div 60^\circ\text{C}$ and mass velocities of $25\div 150\text{ kg}\cdot\text{m}^{-2}\text{ s}^{-1}$. Based on test data, it has been revealed that at the relative side branch mass flow rate above 0.6, the phase separation behaviour does not depend on inlet mass velocity, vapour quality, void fraction, flow patterns (stratified, slug and annular) and relative side branch diameter. A simplified empirical correlation has been proposed describing the ammonia test points with an error margin of $\pm 15\%$.

Many factors impact the phase separation phenomenon in T-junction: the geometry of the T-junction, side branch position, two-phase flow pattern, fluid properties, flow pre-history, gravity orientation, and even the wetting properties of the liquid-solid interface.

A complete understanding of the phase separation in T-junction, from qualitative and quantitative points of view, could help increase the efficiency of such systems and make the performances of future ammonia thermal control systems entirely predictable, which is very important for space and critical ground technology. In this connection, the experimental study dealing with the phase separation of ammonia in T-junctions is valuable and could improve the efficiency of future ammonia systems.

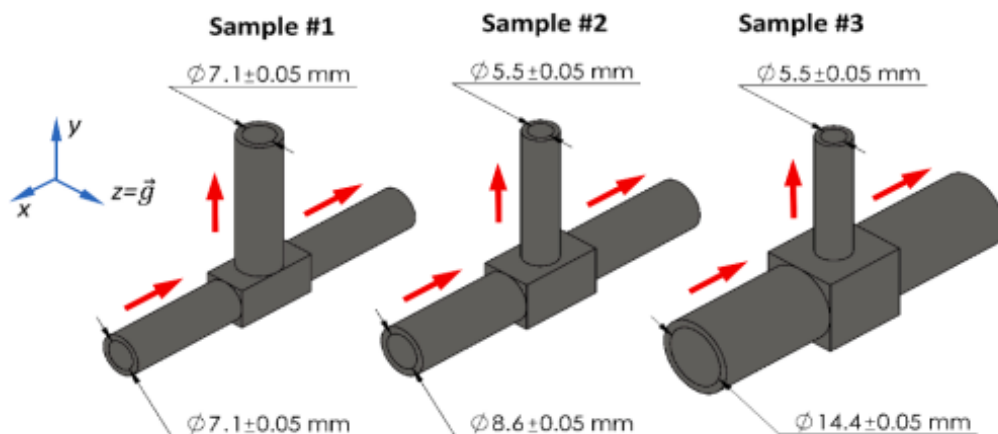

Fig. 1 – Geometry of T-junctions.

The general view of the T-junctions samples is shown in Fig. 1. They have been chosen for the test as the parts of the ammonia mechanically pumped loop in the framework of engineering activity. The samples have been manufactured as a single part by milling. The material of T-junctions is 316 L stainless steel (bar). The machining tools provide the internal surface's roughness of $Ra\ 1.25\ \mu\text{m}$. T-junctions have been checked for the burrs and cleaned with the benzine and IPA fluid in an ultrasonic bath.